

Rudy Cruz, Jr.
Mayor

Ruben Reyes
At Large

Cesar Nevarez
District 1



Alejandro Garcia
District 2

Gina Cordero
District 3/Mayor ProTem

Irene Rojas
District 4

Adriana Rodarte
City Manager

**NOTICE OF REGULAR COUNCIL MEETING
OF THE CITY COUNCIL
OF THE
CITY OF SOCORRO**

.....
THE FACILITY IS WHEELCHAIR ACCESSIBLE AND ACCESSIBLE PARKING SPACES ARE AVAILABLE. REQUESTS FOR ACCOMMODATION FOR INTERPRETIVE SERVICES MUST BE MADE 48 HOURS PRIOR TO THIS MEETING. PLEASE CONTACT THE CITY CLERK'S OFFICE AT (915) 858-2915 FOR FURTHER INFORMATION.

LA INSTALACIÓN ES ACCESIBLE PARA SILLAS DE RUEDAS Y HAY PLAZAS DE ESTACIONAMIENTOS DISPONIBLES. LAS SOLICITUDES DE ADAPTACIÓN PARA SERVICIOS DE TRADUCCIÓN DEBEN HACERSE 48 HORAS ANTES DE ESTA REUNIÓN. COMUNÍQUESE CON LA OFICINA DEL SECRETARIO DE LA CIUDAD AL (915) 858-2915 PARA OBTENER MÁS INFORMACIÓN

.....

NOTICE IS HEREBY GIVEN THAT A REGULAR MEETING OF THE CITY COUNCIL OF THE CITY OF SOCORRO, TEXAS WILL BE HELD ON THURSDAY THE 2ND DAY OF JULY 2026 AT 6:00 PM AT THE CITY HALL CHAMBERS, 860 N. RIO VISTA RD., SOCORRO, TEXAS AT WHICH TIME THE FOLLOWING WILL BE DISCUSSED:

THIS WRITTEN NOTICE, THE MEETING AGENDA, AND THE AGENDA PACKET, ARE POSTED ONLINE AT [HTTP://COSTX.US/CITY-CLERK-PUBLIC-NOTICE](http://costx.us/city-clerk-public-notice) THE PUBLIC CAN ALSO ACCESS THE MEETING BY CALLING TOLL FREE-NUMBER 844-854-2222 ACCESS CODE 323610.

THE PUBLIC MAY CALL IN 844-854-2222 ACCESS CODE 323610 BY 5:30 PM MOUNTAIN STANDARD TIME (MST) ON THE 2ND DAY OF JULY 2026 TO SIGN UP FOR PUBLIC COMMENT AND THE AGENDA ITEM THEY WISH TO COMMENT ON. THE PUBLIC THAT SIGNED UP TO SPEAK WILL BE CALLED UPON BY THE PRESIDING OFFICER DURING THE MEETING.

.....

1. Call to order

2. Pledge of Allegiance and a Moment of Silence.

3. Establishment of Quorum

PUBLIC COMMENT

- 4. Public Comment** (The maximum time for public comment will be 30 minutes and three minutes will be allotted for each speaker. Government Code 551.042 allows for responses by city council to be a statement of specific factual information given in response to the inquiry; or a recitation of existing policy in response to the inquiry; or a decision to add the public comment to a future agenda.)

PRESENTATIONS

- 5. Proclamation** to recognize the Month of July as the City of Socorro's Recreation Appreciation Month. *Victor Reta*
- 6. Presentation** to recognize players, coaches and staff for the 2026 Youth Development Little League. *Victor Reta*

NOTICE TO THE PUBLIC

ALL MATTERS LISTED UNDER THE CONSENT AGENDA, INCLUDING THOSE ON THE ADDENDUM TO THE AGENDA, WILL BE CONSIDERED BY THE CITY COUNCIL TO BE ROUTINE AND WILL BE ENACTED BY ONE MOTION. THERE WILL BE NO SEPARATE DISCUSSION ON THESE ITEMS UNLESS CITY COUNCIL MEMBERS REMOVE SPECIFIC ITEMS FROM THE CONSENT AGENDA TO THE REGULAR AGENDA FOR DISCUSSION PRIOR TO THE TIME THE CITY COUNCIL MEMBERS VOTE ON THE MOTION TO ADOPT THE CONSENT AGENDA.

ITEMS REMOVED FROM THE CONSENT AGENDA TO THE REGULAR AGENDA WILL BE CONSIDERED BY THE CITY COUNCIL AFTER ACTING ON THE CONSENT AGENDA.

ANY MATTERS LISTED ON THE CONSENT AGENDA AND THE REGULAR AGENDA MAY BE DISCUSSED IN EXECUTIVE SESSION AT THE OPTION OF THE CITY OF SOCORRO CITY COUNCIL FOLLOWING VERBAL ANNOUNCEMENT, IF AN APPROPRIATE EXCEPTION TO THE OPEN MEETING REQUIREMENT OF THE TEXAS OPEN MEETINGS ACT IS APPLICABLE.

CONSENT AGENDA

PUBLIC COMMENTS ARE TYPICALLY NOT TAKEN DURING THE INTRODUCTION OF ORDINANCES. PUBLIC COMMENTS WILL BE ALLOWED AT THE SCHEDULED PUBLIC HEARING-ORDINANCE 320

- 7. Excuse** absent council members.

Olivia Navarro

8. **Introduction, First Reading, and Calling for a Public Hearing** of an Ordinance approving a proposed amendment to the City of Socorro's Master Plan and Rezoning of Lot 2, Block 1, Socorro Rehabilitation Subdivision, located on S. Moon Rd., City of Socorro, El Paso County, Texas, from C-2 (General Commercial) to R-1 (Single-Family Residential), to allow for the construction of a residential dwelling. *Lorraine Quimiro*

REGULAR AGENDA
PUBLIC HEARING/ORDINANCE

9. **Public Hearing** of an Ordinance approving a Proposed Amendment to The City Of Socorro's Master Plan and Rezoning of Tracts 17-D & 17-D-1, Block 27, Socorro Grant, Located At 11660 Unit B Socorro Rd., City Of Socorro, El Paso County, Texas, From R-1 (Single Family Residential) To C-1 (Light Commercial), To Allow For Commercial Retail Development. *Lorraine Quimiro*
10. **Second Reading, and Adoption of an Ordinance** approving a Proposed Amendment to The City Of Socorro's Master Plan and Rezoning of Tracts 17-D & 17-D-1, Block 27, Socorro Grant, Located At 11660 Unit B Socorro Rd., City Of Socorro, El Paso County, Texas, From R-1 (Single Family Residential) To C-1 (Light Commercial), To Allow For Commercial Retail Development. *Lorraine Quimiro*
11. **Public Hearing** on Ordinance 695 Amendment No. 2, Decreasing the Fiscal Year 2025-2026 Budget by \$270.00. *Adriana Rodarte*
12. **Second Reading and Adoption** on Ordinance 695 Amendment No. 2, Decreasing the Fiscal Year 2025-2026 Budget by \$270.00. *Adriana Rodarte*

GRANTS DEPARTMENT

13. **Discussion and action** to approve Resolution 845 authorizing the submission of a grant application to the Texas Parks and Wildlife Department (TPWD) Local Park Grants Program for the Socorro Parks Improvements Phase I Project, and to authorize a required 50 percent local match. *Alejandra Valadez*

PLANNING AND ZONING DEPARTMENT

14. **Discussion and action** to approve Resolution 846 authorizing Mayor to sign the City Pride Sign Agreement between the State of Texas and the City of Socorro, to participate in the Texas Department of Transportation City Pride Sign Program. *Lorraine Quimiro*

MAYOR AND COUNCIL

15. **Discussion and action** to Direct Staff to Research and Prepare Recommendations Regarding the Regulation of Shipping Container Homes and Commercial use within the City. *Mayor Rudy Cruz, Jr.*

EXECUTIVE SESSION

The City Council of the City of Socorro may retire into EXECUTIVE SESSION pursuant to Section 3.08 of the City of Socorro Charter and the Texas Government Code, Sections 551, Subchapter D to discuss any of the following: (The items listed below are matters of the sort routinely discuss in Executive Session, but the City Council of the City of Socorro may move to Executive Session any of the items on this agenda, consistent with the terms of the Open Meetings Act.) The City Council will return to open session to take any final action and may also, at any time during the meeting, bring forward any of the following items for public discussion, as appropriate.

- Section 551.071 CONSULTATIONS WITH ATTORNEY
- Section 551.072 DELIBERATION REGARDING REAL PROPERTY
- Section 551.073 DELIBERATION REGARDING PROSPECTIVE GIFT
- Section 551.074 PERSONNEL MATTERS
- Section 551.076 DELIBERATION REGARDING SECURITY
- Section 551.087 DELIBERATION REGARDING ECONOMIC DEVELOPMENT NEGOTIATIONS

Discussion on the following:

16. ***Discussion and action*** on advice received from City Attorney in closed session, and action to approve real estate transaction; authorize filing or settlement of legal action; authorize employment of expert witnesses and consultants, and employment of special counsel with respect to pending legal matters.

Adriana Rodarte
17. ***Discussion and action*** on qualifications of individuals for employment and for appointment to Boards & Commissions, job performance of employees, real estate acquisition and receive legal advice from City Attorney regarding legal issues affecting these matters.

Adriana Rodarte
18. ***Discussion and action*** regarding pending litigation and receive status report regarding pending litigation.

Adriana Rodarte
19. ***Discussion*** on a potential economic development opportunity in Socorro. Project Mist; (551.087)

Alejandra Valadez
20. ***Adjourn***

DATED THIS 26th DAY OF JUNE 2026

By: 
Olivia Navarro, City Clerk

I, the undersigned authority, hereby certify that the above notice of the meeting of the City Council of Socorro, Texas is a correct copy of the notice and that I posted this notice at least Seventy-two (72) hours preceding the scheduled meeting at the City Administration Building, 124 S. Horizon Blvd., in Socorro, Texas.

DATED THIS 26th OF JUNE 2026

By: 
Olivia Navarro, City Clerk

Agenda posted: 6-26-26 @ 2:42
Removed: _____ Time: _____ by: _____

ITEM 5

Rudy Cruz Jr.
Mayor

Ruben Reyes
At Large

Cesar Nevarez
District 1



Alejandro Garcia
District 2

Gina Cordero
District 3/ Mayor Pro-Tem

Irene Rojas
District 4

Adriana Rodarte
City Manager

June 24, 2026

TO: City Clerk: Olivia Navarro

FROM: Victor Reta; Division Director of: Recreation, Communications, Special Events, Emergency Management, Legislative Affairs, & Transit
Serves as: Public Information Officer & Historic Preservation Officer

SUBJECT: Proclamation to recognize the Month of July as the City of Socorro's Recreation Appreciation Month

SUMMARY: Nationally across the county, July is recognized as National Recreation Month. I am requesting Council to pass this proclamation and recognize my department staff for all their hard work & dedication to the City.

STATEMENT OF THE ISSUE: As per City Policy, we are requesting Mayor make this proclamation official.

FINANCIAL IMPACT: N/A

ALTERNATIVE: N/A

STAFF RECOMMENDATION: Approval

REQUIRED AUTHORIZATION:

REQUIRED AUTHORIZATION:

1. City Manager _____ Date _____
2. CFO _____ Date _____
3. Attorney _____ Date _____

Rudy Cruz, Jr.
Mayor

Ruben Reyes
At-Large

Cesar Nevarez
District 1



Alejandro Garcia
District 2

Gina Cordero.
District 3/ Mayor Pro Tem

Irene Rojas
District 4

Office of the Mayor Proclamation

WHEREAS Recreation is an integral part of communities throughout this country, including the City of Socorro, Texas; and

WHEREAS our Recreation Department is vitally important to establishing and maintaining the quality of life in our communities, ensuring the health of all community members, and contributing to the well-being of a community and region; and,

WHEREAS our Recreation Department is a leading provider of healthy meals, nutrition services, and education aimed at building healthy, active communities that aid in the prevention of chronic disease, provide therapeutic recreation services for individuals with disabilities, and also improve the mental and emotional health of all residents; and

WHEREAS our Recreation is fundamental to the environmental well-being of our community by increasing our community's economic prosperity through expansion of the local tax base, increased tourism, the attraction and retention of businesses, and crime reduction; and

WHEREAS our Recreation areas ensure the ecological beauty of our community and provide a place for children and adults to connect with nature and recreate outdoors; and

WHEREAS our Recreation Department serves as the programmers and coordinators of several campaigns, events, and initiatives in the areas of recreation, communication, emergency response, historic preservation, and overall civic affairs: often representing the City as Ambassadors on a local, state, and national stage.

NOW THEREFORE, BE IT RESOLVED I, Rudy Cruz Jr., Mayor of the City of Socorro along with the Socorro City Council, do hereby proclaim the month of July be recognized as Recreation Month in the City of Socorro, Texas.

Dated this 2nd day of July, 2026.

CITY OF SOCORRO

Rudy Cruz Jr. Mayor

ATTEST:

Olivia Navarro, City Clerk

Rudy Cruz Jr.
Mayor

Ruben Reyes
At Large

Cesar Nevarez
District 1



Alejandro Garcia
District 2

Gina Cordero
District 3/ Mayor Pro-Tem

Irene Rojas
District 4

Adriana Rodarte
District 5

June 24, 2026

TO: City Clerk: Olivia Navarro

FROM: Victor Reta; Division Director of: Recreation, Communication, Special Events, Emergency Management & Legislative Affairs

Serves as: Public Information Officer & Historic Preservation Officer

SUBJECT: *Presentation to recognize players, coaches and staff for the 2026 Youth Development Little League*

SUMMARY: The 8 week youth development league has completed their 2025 summer season and would like to recognize the kids, volunteer coaches and staff for a great summer season.

STATEMENT OF THE ISSUE: No issue

STATEMENT OF THE ISSUE: N/A

FINANCIAL IMPACT: N/A

STAFF RECOMMENDATION: N/A

ALTERNATIVE: N/A

REQUIRED AUTHORIZATION:

1. City Manager _____ Date _____
2. CFO _____ Date _____
3. Attorney _____ Date _____



**CITY OF SOCORRO
CITY COUNCIL**

**MEETING DATE: JULY 2, 2026
REZONING REQUEST STAFF
REPORT**

SUBJECT: INTRODUCTION, FIRST READING, AND CALLING FOR A PUBLIC HEARING OF AN ORDINANCE APPROVING A PROPOSED AMENDMENT TO THE CITY OF SOCORRO'S MASTER PLAN AND REZONING OF LOT 2, BLOCK 1, SOCORRO REHABILITATION SUBDIVISION, LOCATED ON S. MOON RD., CITY OF SOCORRO, EL PASO COUNTY, TEXAS, FROM C-2 (GENERAL COMMERCIAL) TO R-1 (SINGLE-FAMILY RESIDENTIAL), TO ALLOW FOR THE CONSTRUCTION OF A RESIDENTIAL DWELLING.

NAME: S. Moon Rd. Rezoning

PROPERTY ADDRESS: S. Moon Rd.

PROPERTY LEGAL DESCRIPTION: Lot 2, Block 1, Socorro Rehabilitation Subdivision

PROPERTY OWNER: Jesus Cortes

REPRESENTATIVE: Jesus Cortes

PROPERTY AREA: 46,425.54 Sq Ft. (1.056 Acres)

CURRENT ZONING: C-2 (General Commercial)

CURRENT LAND USE: Vacant

FUTURE LAND USE MAP: Mixed-Use

FLOOD MAP: According to the Flood Insurance Rate Maps, The referenced Property Lies Within Zone X (Community Panel # 480212 0236-B/ FEMA, September 4, 1991.

SUMMARY OF REQUEST: Request is for approval of a rezoning of a property from C-2 (General Commercial) to R-1 (Single-Family Residential) to allow for construction of a residential dwelling.

STAFF RECOMMENDATION: Staff recommends **APPROVAL** of the rezoning request.

PLANNING & ZONING RECOMMENDATION: Planning and Zoning Commission voted for **APPROVAL** (3-Yes, 0-No, 1-Abstain) of the rezoning request at their June 16, 2026 meeting.

Rudy Cruz, Jr.
Mayor

Ruben Reyes
Representative
At Large

Cesar Nevarez
District 1



Alejandro Garcia
District 2

Gina Cordero
District 3 / Mayor Pro Tem

Irene Rojas
District 4

Adriana Rodarte
City Manager

ORDINANCE _____

AN ORDINANCE APPROVING A REZONING OF LOT 2, BLOCK 1, SOCORRO REHABILITATION SUBDIVISION, LOCATED ON S. MOON RD., CITY OF SOCORRO, EL PASO COUNTY TEXAS, FROM C-2 (GENERAL COMMERCIAL) TO R-1 (SINGLE-FAMILY RESIDENTIAL), TO ALLOW FOR THE CONSTRUCTION OF A RESIDENTIAL DWELLING.

NOW THEREFORE, BE IT ORDAINED BY THE CITY COUNCIL OF THE CITY OF SOCORRO:

That pursuant to Chapter 46 of the Codification of Ordinances of the City of Socorro, Texas, the Zoning Ordinance of the City of Socorro, that the property being Lot 2, Block 1, Socorro Rehabilitation Subdivision, located on S. Moon Rd., City of Socorro, El Paso County Texas, from C-2 (General Commercial) to R-1 (Single-Family Residential), to allow for the construction of a residential dwelling.

READ, APPROVED AND ADOPTED this _____ day of ____ 2026.

CITY OF SOCORRO, TEXAS

Rudy Cruz Jr., Mayor

ATTEST:

Olivia Navarro, City Clerk

APPROVED AS TO FORM:

James A. Martinez
Socorro City Attorney

Introduction, First Reading and Calling for a Public Hearing: July 2, 2026
Second Reading and Adoption:

ZONING MAP

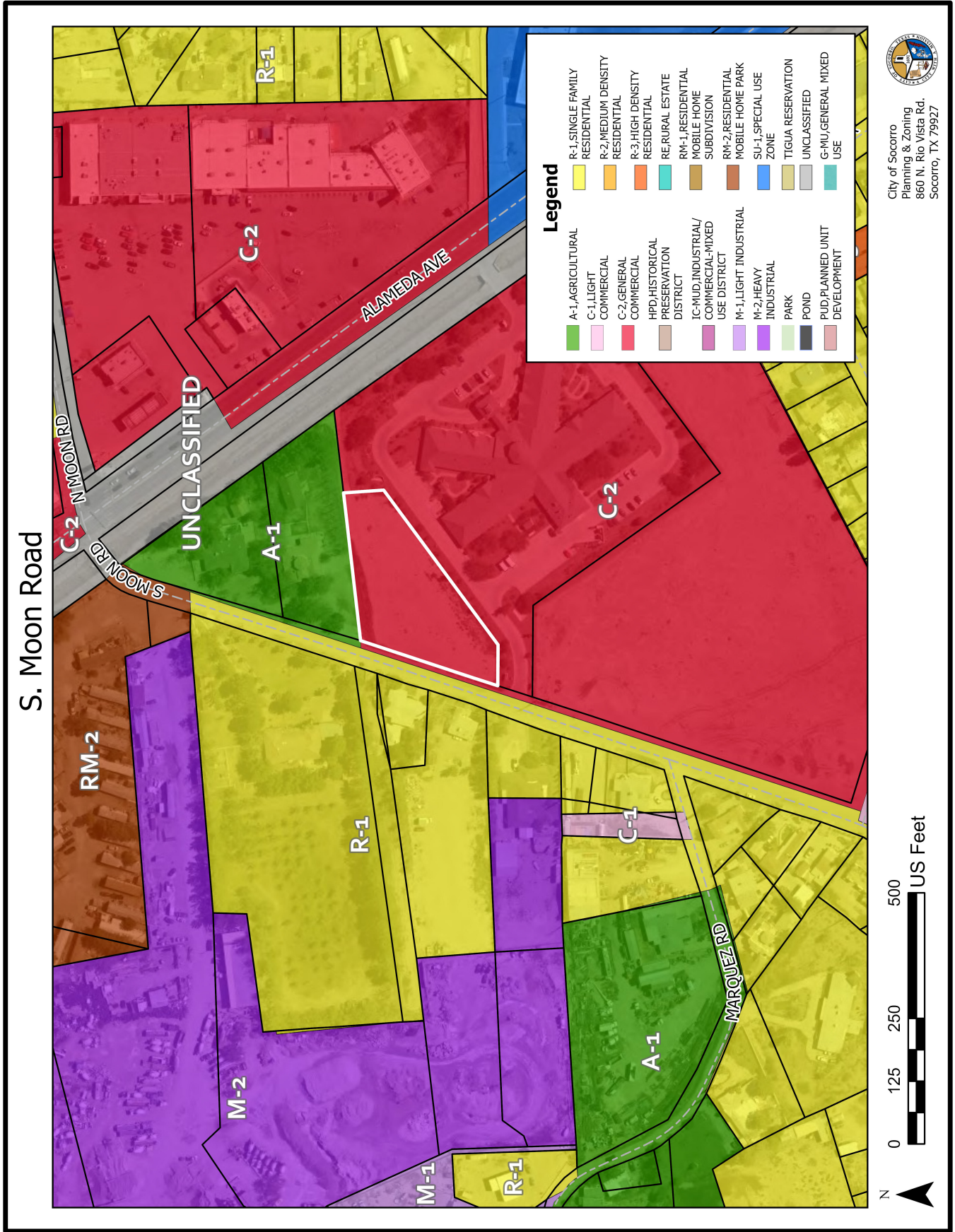

AERIAL MAP

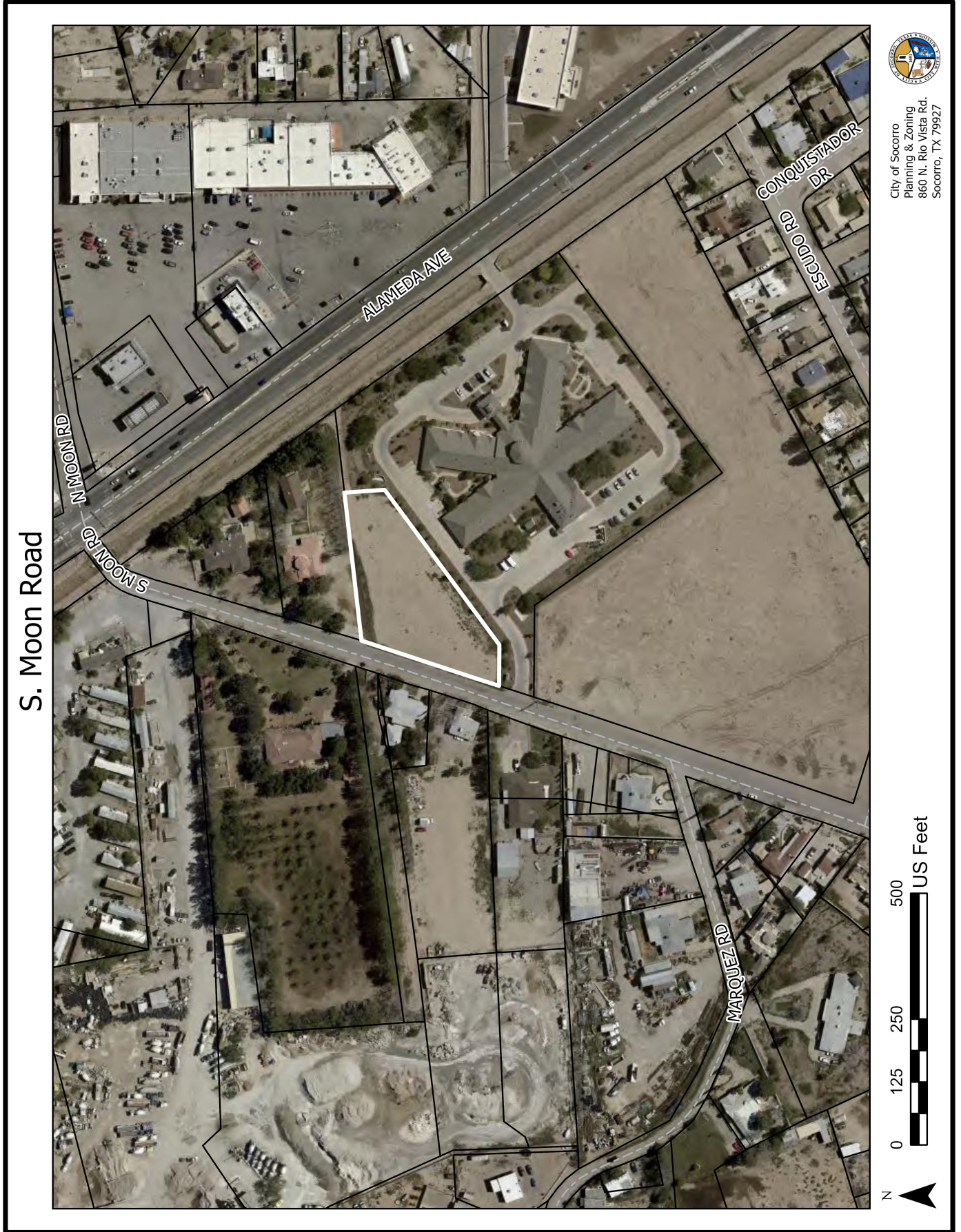

S. Moon Road

N MOON RD

S MOON RD

ALAMEDA AVE

MARQUEZ RD

CONQUISTADOR DR

ESCUDO RD



City of Socorro
Planning & Zoning
860 N. Rico Vista Rd.
Socorro, TX 79927



SITE PICTURES

Front view of the subject property as seen from S. Moon Road.



Rear view of the subject property facing S. Moon Road. ↓



200' AROUND MAP

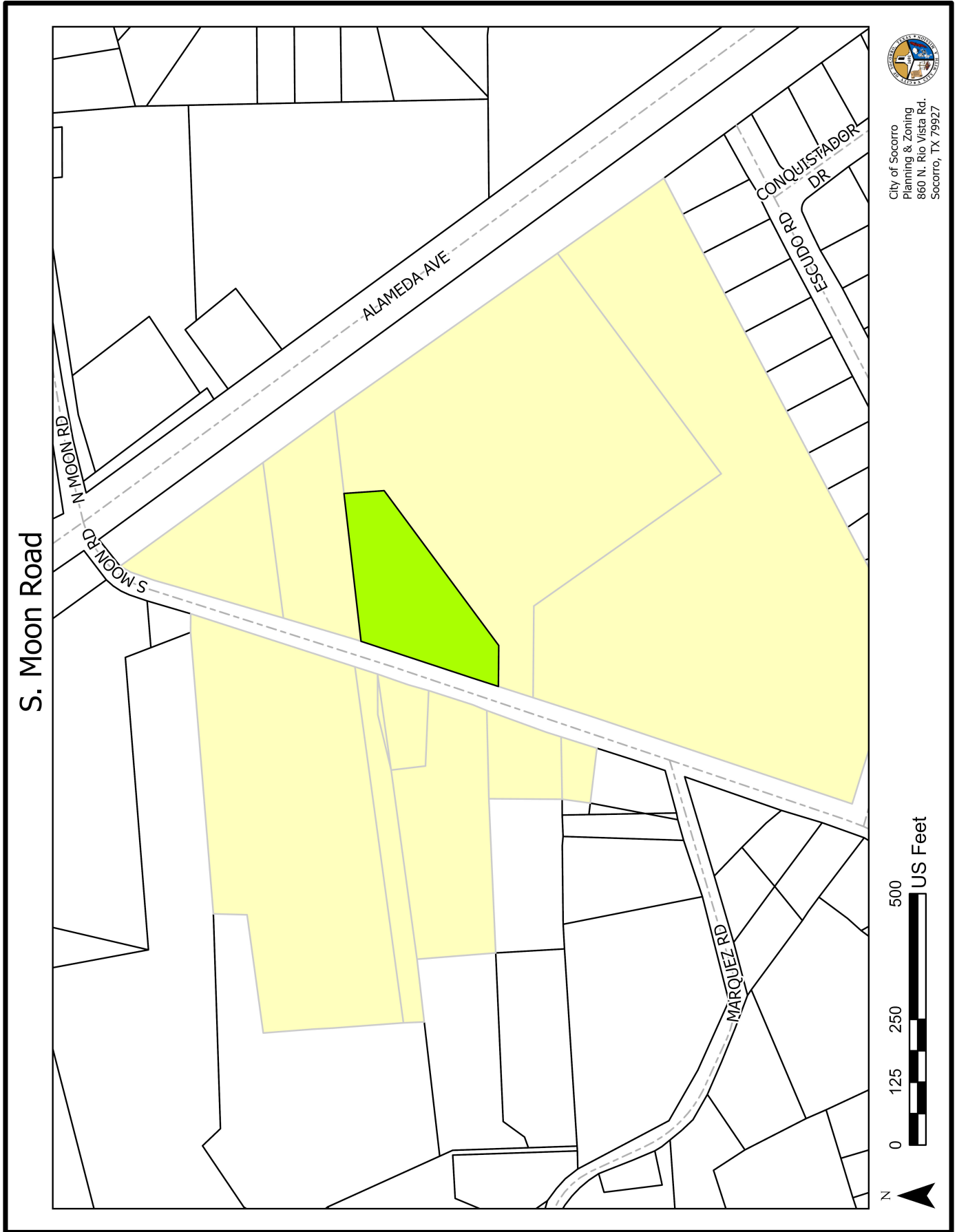

City of Socorro
Planning & Zoning
860 N. Rico Vista Rd.
Socorro, TX 79927



CITY OF SOCORRO CITY COUNCIL

MEETING DATE: JULY 2, 2026

REZONING REQUEST STAFF REPORT

SUBJECT: SECOND READING, AND ADOPTION OF AN ORDINANCE APPROVING A PROPOSED AMENDMENT TO THE CITY OF SOCORRO'S MASTER PLAN AND REZONING OF TRACTS 17-D & 17-D-1, BLOCK 27, SOCORRO GRANT, LOCATED AT 11660 UNIT B SOCORRO RD., CITY OF SOCORRO, EL PASO COUNTY, TEXAS, FROM R-1 (SINGLE FAMILY RESIDENTIAL) TO C-1 (LIGHT COMMERCIAL), TO ALLOW FOR COMMERCIAL RETAIL DEVELOPMENT.

NAME: 11660 Unit B Socorro Rd. Rezoning

PROPERTY ADDRESS: 11660 Unit B Socorro Rd.

PROPERTY LEGAL DESCRIPTION: Tracts 17-D & 17-D-1, Block 27, Socorro Grant

PROPERTY OWNER: Victor Pantoja-Nunez

REPRESENTATIVE: Samuel A. Leony / Greater El Paso Design and Construction Group LLC

PROPERTY AREA: 44,605.44 Sq Ft. (1.024 Acres)

CURRENT ZONING: R1 (Residential)

CURRENT LAND USE: Vacant

FUTURE LAND USE MAP: Rural Residential

FLOOD MAP: According to the Flood Insurance Rate Maps, The referenced Property Lies Within Zone X (Community Panel # 480212 0300-B/ FEMA, September 4, 1991.

SUMMARY OF REQUEST: Request is for approval of a rezoning of a property from R-1 (Single Family Residential) to C-1 (Light Commercial), to allow for commercial retail development.

STAFF RECOMMENDATION: Staff recommends **APPROVAL** of the rezoning request.

PLANNING & ZONING RECOMMENDATION: Planning and Zoning Commission voted for **APPROVAL** (3-Yes, 0-No, 1-Abstain) of the rezoning request at their June 2, 2026 meeting.

Rudy Cruz, Jr.
Mayor

Ruben Reyes
Representative
At Large

Cesar Nevarez
District 1



Alejandro Garcia
District 2

Gina Cordero
District 3 / Mayor Pro Tem

Irene Rojas
District 4

Adriana Rodarte
City Manager

ORDINANCE _____

AN ORDINANCE APPROVING A REZONING OF TRACTS 17-D & 17-D-1, BLOCK 27, SOCORRO GRANT, LOCATED AT 11660 UNIT B SOCORRO RD., CITY OF SOCORRO, EL PASO COUNTY TEXAS, FROM R-1 (SINGLE FAMILY RESIDENTIAL) TO C-1 (LIGHT COMMERCIAL), TO ALLOW FOR COMMERCIAL RETAIL DEVELOPMENT.

NOW THEREFORE, BE IT ORDAINED BY THE CITY COUNCIL OF THE CITY OF SOCORRO:

That pursuant to Chapter 46 of the Codification of Ordinances of the City of Socorro, Texas, the Zoning Ordinance of the City of Socorro, that the property being, Tracts 17-D-1 & 17-D-1, Block 27, Socorro Grant, located at 11660 Unit B Socorro Rd., City of Socorro, El Paso County Texas, from R-1 (Single Family Residential) to C-1 (Light Commercial), to allow for commercial retail development.

READ, APPROVED AND ADOPTED this _____ day of ____ 2026.

CITY OF SOCORRO, TEXAS

Rudy Cruz Jr., Mayor

ATTEST:

Olivia Navarro, City Clerk

APPROVED AS TO FORM:

James A. Martinez
Socorro City Attorney

Introduction, First Reading and Calling for a Public Hearing: June 25, 2026
Second Reading and Adoption: July 2, 2026

ZONING MAP

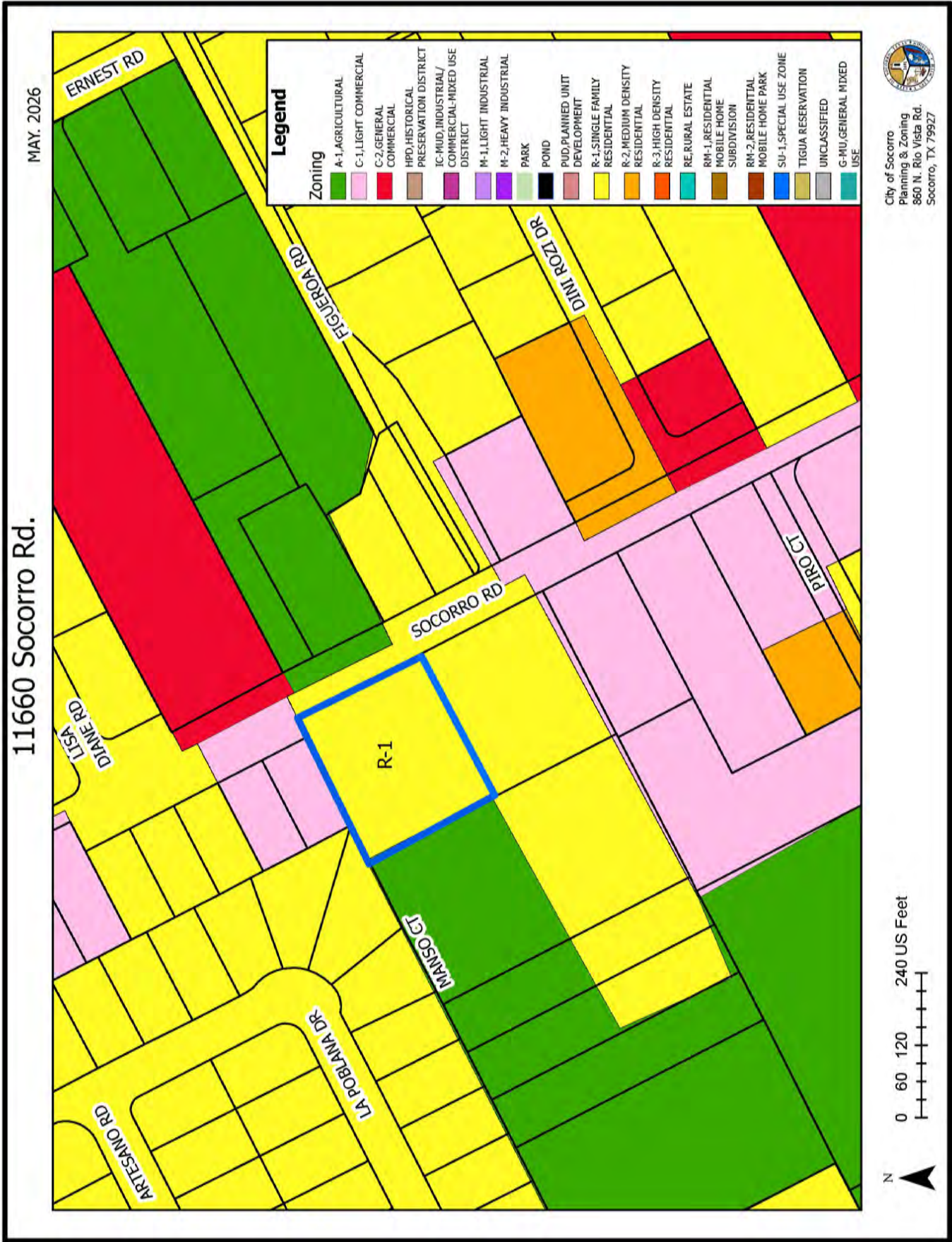

2040 FUTURE LAND USE MAP

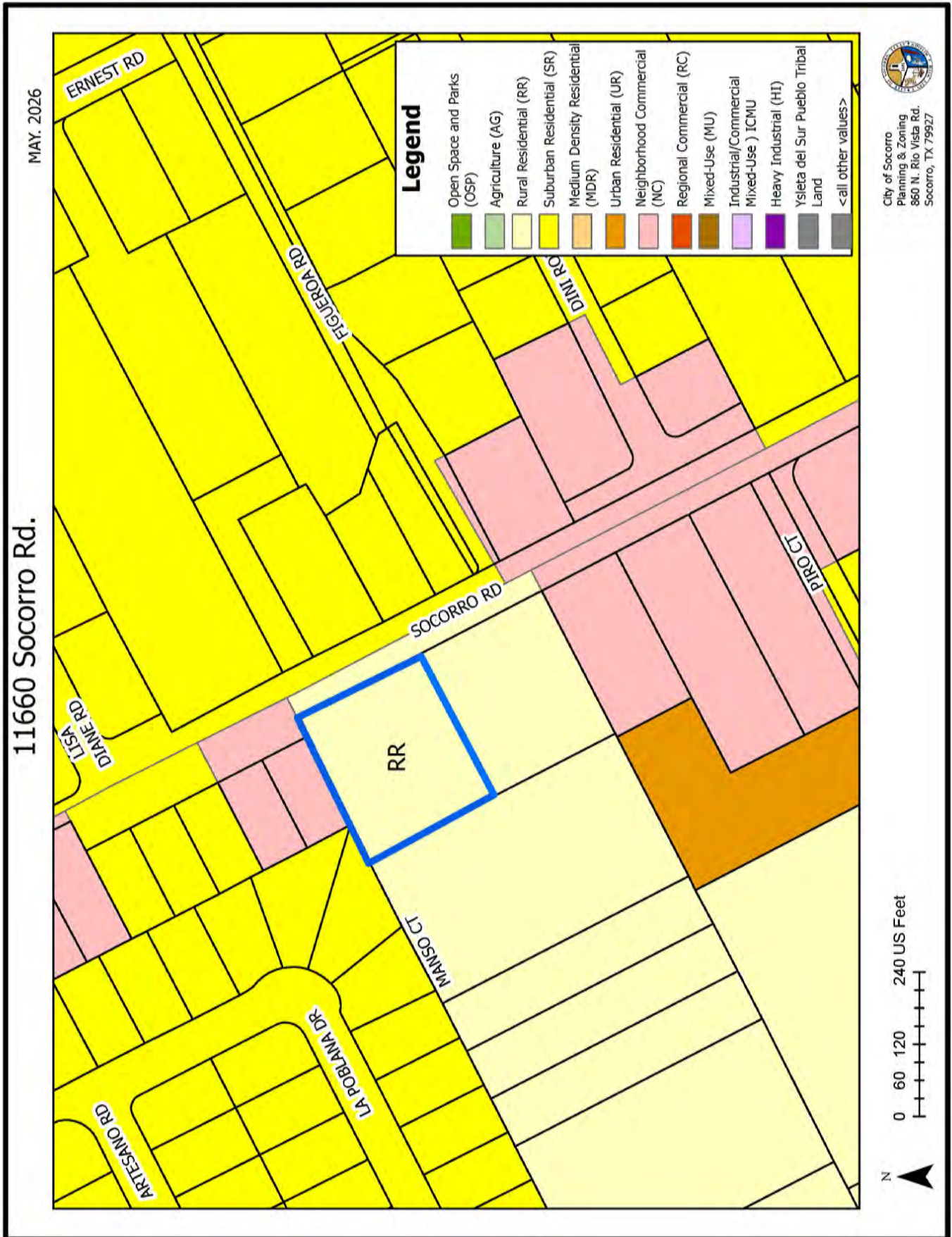

AERIAL MAP

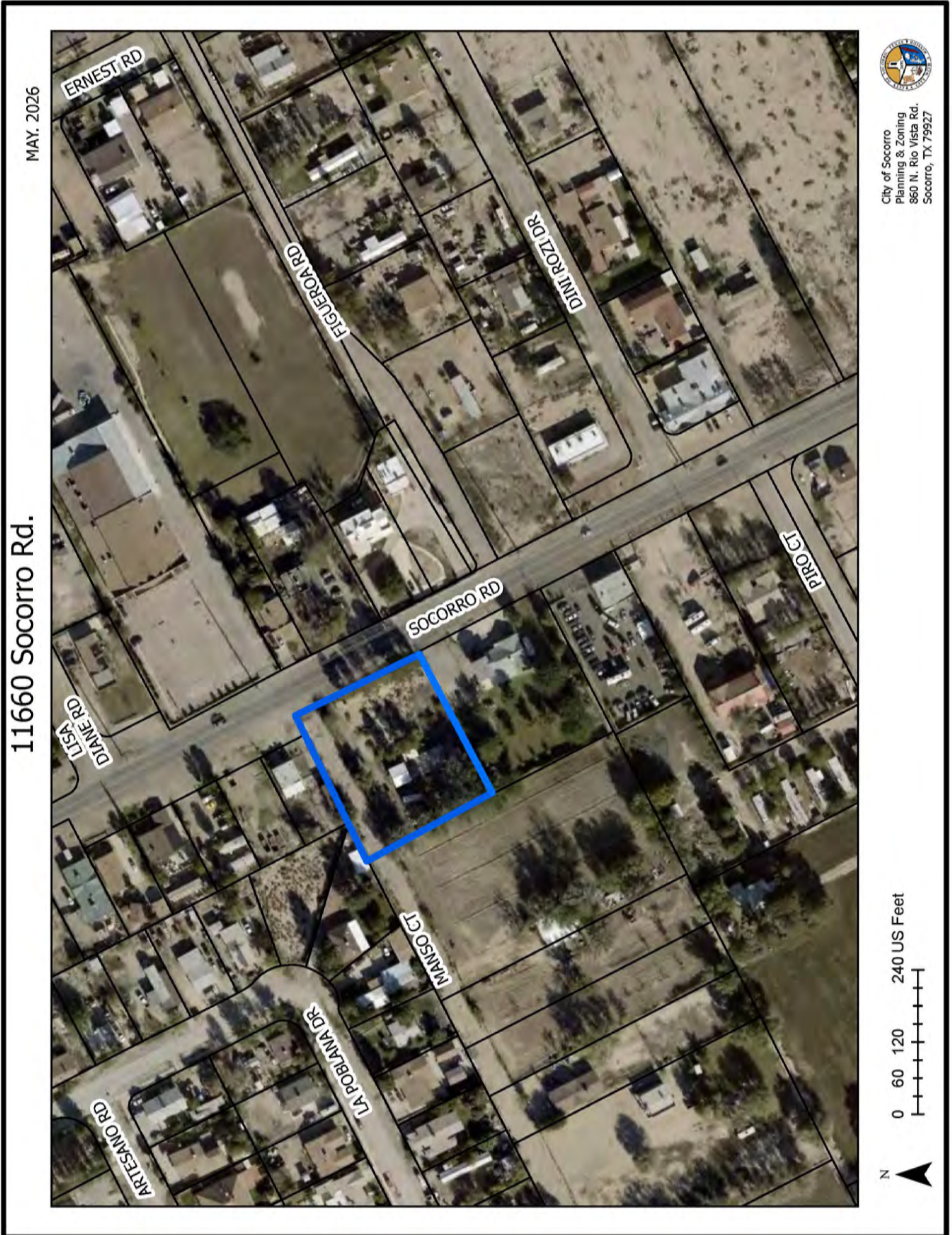

City of Socorro
Planning & Zoning
860 N. Rio Vista Rd.
Socorro, TX 79927

SITE PICTURES

VIEW FROM SOCORRO RD.



VIEW OF MANSO CT ACCESS



VIEW OF FRONT OF PROPERTY



200' AROUND MAP



SITE PLAN

TRACT 17E, BLOCK 27,
SOCORRO GRANT
VOL 1959 PG 1393

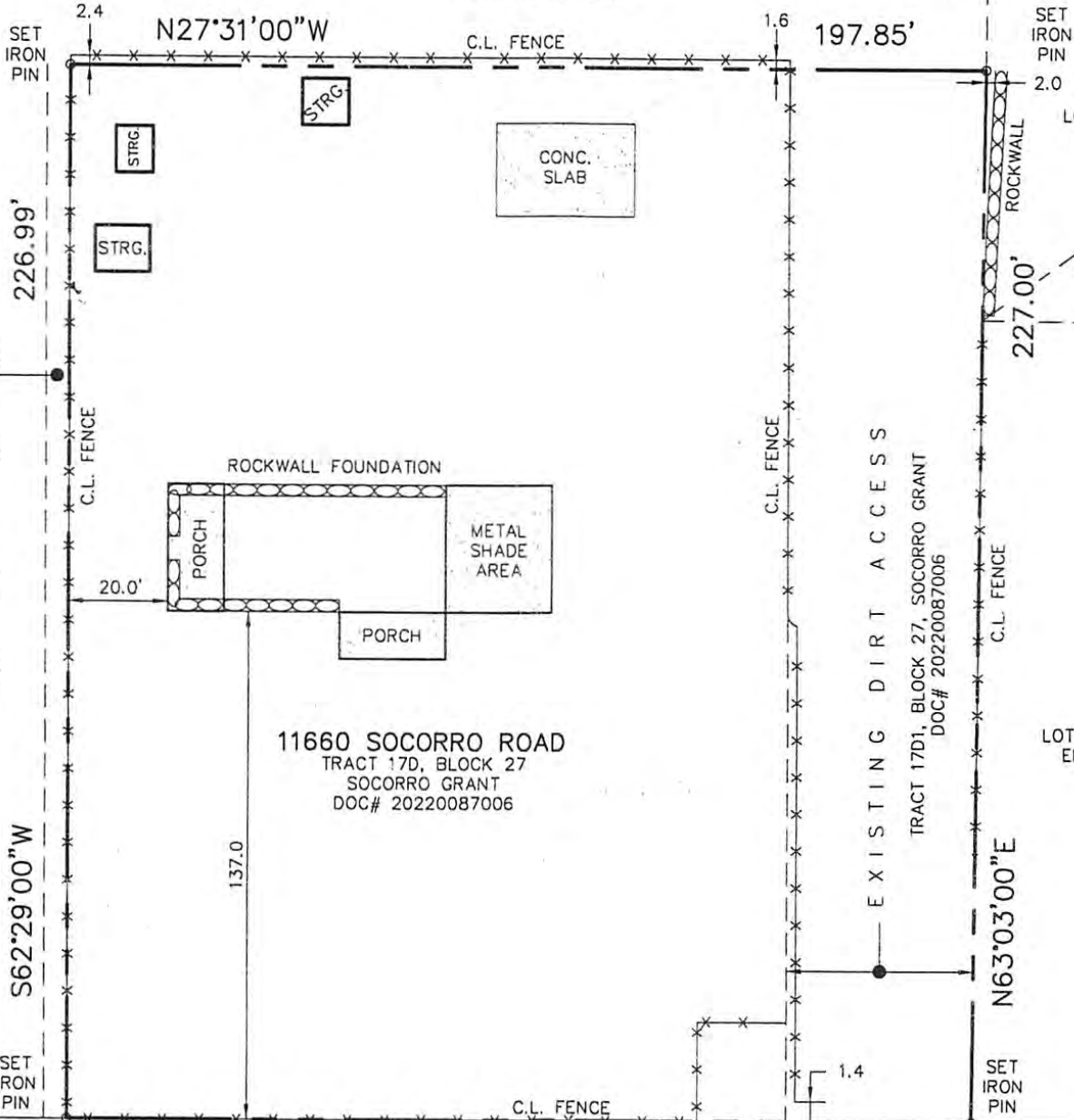

S27°31'00"E

EDGE OF PAVEMENT

S O C O R R O R O A D

S27°31'00"E (BEARING BASIS)

30.0

CONCEPTUAL PLAN

GREATER DESIGN AND CONSTRUCTION GROUP, LTD.
 8904 CAMARINA PL. • EL PASO, TEXAS 79906 • TEL. (915) 809-0001
EL PASO

PROJECT AREA:
 3,750 SQ.FT.
SCALE:
 AS SHOWN
DATE:
 03/2026

PROJECT: RE-ZONING PROJECT
ADDRESS: 11660-B SOCORRO RD., SOCORRO, TEXAS 79927
LEGAL: 27 SOCORRO 17-D (0.81 AC) & 17-D-1 (0.214 AC)
OWNER: VICTOR PANTOJA-NUÑEZ
 DWG. NO. 1 OF 1

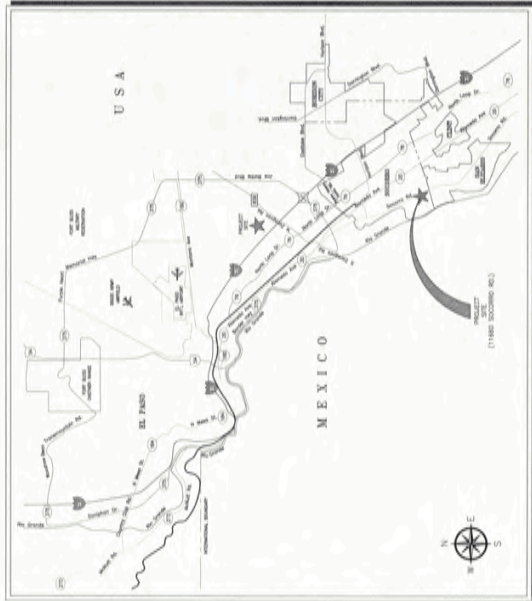

AREA MAP
Scale: 1"=1000'

SYMBOL LEGEND	
	FEDERAL HIGHWAY
	STATE HIGHWAY
	COUNTY ROAD
	CITY STREET
	INTERNAL TRAFFIC DIRECTION
	NO PARKING ZONE
	ADA ACCESSIBLE SPACE
	ADA PARKING SIGN POLE
	PROJECT SITE

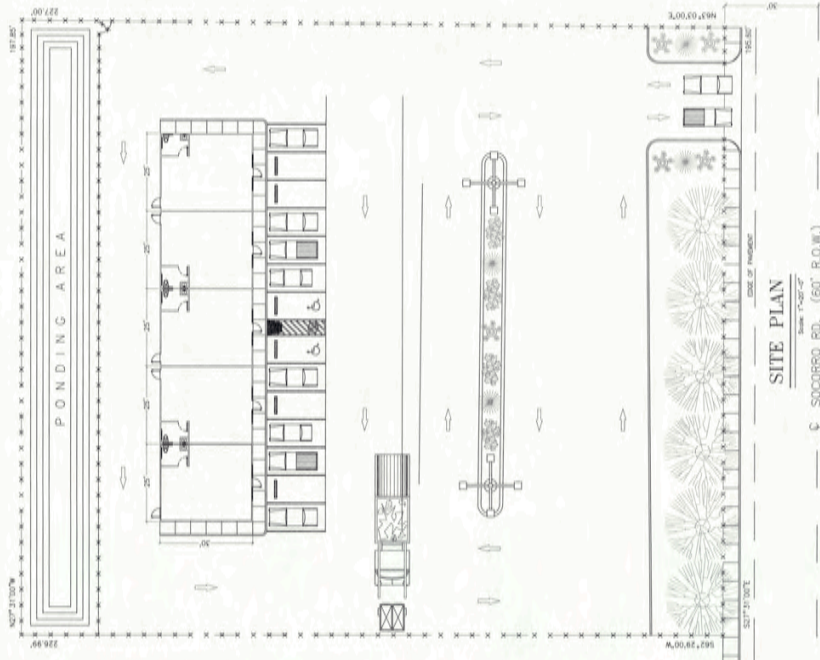

SITE PLAN
Scale: 1"=60' (P.O.M.)

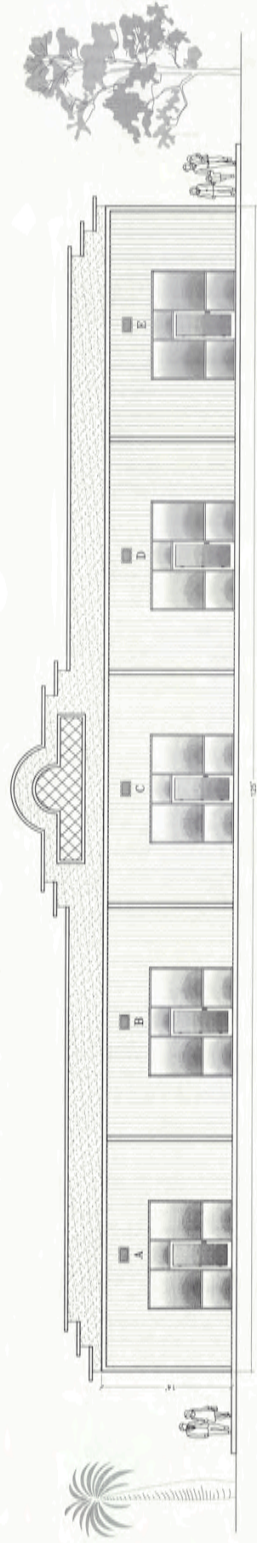

FRONT ELEVATION
Scale: 1"=60'

Rudy Cruz, Jr.
Mayor

Ruben Reyes
At Large

Cesar Nevarez
District 1/ Mayor ProTem



Alejandro Garcia
District 2

Gina Cordero
District 3

Irene Rojas
District 4

DATE: JUNE 24, 2026

TO: MAYOR AND CITY COUNCIL MEMBERS

FROM: CITY MANAGER, ADRIANA RODARTE

SUBJECT:

Public Hearing and Second Reading and Adoption on Ordinance 695, Amendment No. 2, Decreasing the Fiscal Year 2025-2026 Budget by \$270.00

SUMMARY

Mayor and Council are requested to consider the introduction, first reading of Ordinance NO. 695, Amendment No. 2, which proposes to decrease the Fiscal Year 2025-2026 budget in the amount of \$270.00 and to call for a public hearing on the proposed amendment.

BACKGROUND

This amendment adjusts the Fiscal Year 2025-2026 budget to reflect updated financial information and ensure the City's budget accurately represents current revenues and expenditures. The proposed amendment would decrease the overall budget by \$270.00

In accordance with City procedures and state requirements, the ordinance must be introduced, read for the first time, and a public hearing scheduled prior to adoption.

STATEMENT OF THE ISSUE

Funding source: General Fund

Amount: Decrease Expenditures by \$270.00

ALTERNATIVE: Deny request

STAFF RECOMMENDATION: Approve

Rudy Cruz, Jr.
Mayor

Ruben Reyes
At-Large

Cesar Nevarez
District 1



Alejandro Garcia
District 2

Gina Cordero
District 3/ Mayor ProTem

Irene Rojas
District 4

**ORDINANCE NO. 695
AMENDMENT NO. 2**

**AN ORDINANCE OF THE CITY OF SOCORRO, TEXAS ADOPTING AN
AMENDED BUDGET TO DECREASE FY 2025- 2026 ADOPTED BUDGET**

WHEREAS, it appears that it is necessary and desirable for the City Council to balance the City's General Fund Budget to decrease expenditures by **\$270.00** (see Exhibit A); and

NOW THEREFORE BE IT ORDAINED BY THE CITY COUNCIL OF THE CITY OF SOCORRO, TEXAS, THAT;

SECTION 1. FINDINGS:

That the matters and facts stated in the preamble hereof be, and same are hereby found and adjudicated to be true and correct.

SECTION 2. AMENDED BUDGET;

That this is the 2nd Amendment Budget for 2025-2026 of the City of Socorro, Texas which is attached hereto as **Exhibit "A"** and incorporated herein for all purposes, is hereby approved and adopted by the City Council to be effective immediately.

SECTION 3. REPEAL OF CONFLICTING ORDINANCES:

That all Ordinances of the City of Socorro, Texas or parts thereof, that conflict with this Ordinance are, to the extent of said conflict, hereby repealed, but only to the extent of said conflict.

SECTION 4. EFFECTIVE DATE:

That this Ordinance was duly enacted with all requisites and formalities incident thereto and such is evidenced by the signature affixed below.

**PASSED AND APPROVED BY THE CITY COUNCIL OF THE CITY OF
SOCORRO, TEXAS, this _____ day of _____, 2026.**

Rudy Cruz, Jr., Mayor

ATTEST:

Olivia Navarro, City Clerk

APPROVED AS TO FORM:

James Martinez, City Attorney

Introduction, First Reading and Calling for a Public Hearing: June 25, 2026
Second Reading and Adoption: July 2, 2026

City of Socorro
 Detail Budget/Actual Transactions - LG - Budget Rpt for the Depts
 From 10/1/2025 Through 2/28/2026

00002 - City
 Manager

GL Code	GL Title	Revised Budget	Increase	Decrease	Amended	Actual	Encumbrance	Available Budget
05101	Salaries	635,086.00			635,086.00	438,654.68	0.00	196,431.32
05103	Overtime	10,000.00			10,000.00	4,885.12	0.00	5,114.88
05111	FICA/Medicare Taxes	49,349.00			49,349.00	32,228.68	0.00	17,120.32
05112	T.W.C. Payroll Taxes	3,120.00			3,120.00	1,321.92	0.00	1,798.08
05113	Health Insurance Premiums	105,600.00		(10,000.00)	95,600.00	62,374.17	0.00	33,225.83
05114	Workers Compensation Insurance	21,100.00		(5,000.00)	16,100.00	4,822.25	0.00	11,277.75
05115	Deferred Compensation Benefits	8,500.00	10,000.00		18,500.00	15,052.35	0.00	3,447.65
05116	Life Insurance	1,006.00	80.00		1,086.00	1,071.36	0.00	14.64
05117	Dental Insurance Expense	2,424.00	400.00		2,824.00	2,723.72	0.00	100.28
05118	Vision Insurance Expense	756.00			756.00	526.94	0.00	229.06
05119	Employee Assistance Program	50.00			50.00	0.00	0.00	50.00
05120	FUTA Payroll Taxes	100.00			100.00	0.00	0.00	100.00
05121	Payroll Fees	300.00			300.00	266.83	0.00	33.17
05201	Office Expense and Supplies	15,000.00			15,000.00	5,402.13	1,796.17	7,801.70
05211	Postage	3,000.00			3,000.00	1,706.25	793.75	500.00
05212	Tools and Supplies	11,500.00			11,500.00	8,614.88	858.02	2,027.10
05213	Uniforms	7,000.00			7,000.00	4,929.98	951.07	1,118.95
05310	Building Modifications/A.D.A.	500.00			500.00	6.00	0.00	500.00
05311	Building & Property Maintenance	7,000.00			7,000.00	4,851.85	0.00	2,148.15
05313	Utilities	27,000.00	16,000.00		43,000.00	37,354.54	0.00	5,645.46
05314	Telephone	43,000.00		(16,000.00)	27,000.00	16,045.64	0.00	10,954.36
05411	Legal Fees	70,000.00		(5,000.00)	65,000.00	4,832.06	7,792.90	52,375.04
05510	Property Insurance	5,000.00			5,000.00	3,262.49	0.00	1,737.51
05516	Dues/Subscriptions	13,000.00			13,000.00	6,838.89	0.00	6,161.11
05518	Liability Insurance	5,000.00			5,000.00	4,335.87	0.00	664.13
05520	Service Contracts	1,010,000.00	126,000.00		1,136,000.00	817,134.21	203,361.84	115,503.95
05521	Support Activities	50,000.00			50,000.00	21,134.33	3,927.00	24,938.67
05523	Equipment Rental/Lease	18,000.00			18,000.00	10,010.78	5,238.64	2,750.58
05527	Seminars/Training/Workshops	16,000.00			16,000.00	4,609.00	0.00	11,391.00
05546	Marketing Exp	5,000.00			5,000.00	150.79	0.00	4,849.21
05612	Vehicle Repair & Maintenance	8,000.00			8,000.00	3,486.73	0.00	4,513.27
05613	Equipment Repair & Maintenance	2,000.00			2,000.00	0.00	0.00	2,000.00
05614	Vehicle Fuel	10,000.00			10,000.00	6,075.94	0.00	3,924.06

City of Socorro
 Detail Budget/Actual Transactions - LG - Budget Rpt for the Depts
 From 10/1/2025 Through 2/28/2026

05711	Travel Lodg Airf Mil	23,000.00		23,000.00	9,533.99	0.00	13,466.01
05810	Property and Equipment	50,000.00		30,000.00	3,759.68	0.00	26,240.32
05900	Emergency Aid and Assistance	10,000.00		10,000.00	0.00	0.00	10,000.00
	Balance 00002 - City Manager	2,246,391.00	152,480.00	(56,000.00)	2,342,871.00	1,537,998.05	224,719.39
							580,153.56

City of Socorro
 Detail Budget/Actual Transactions - LG - Budget Rpt for the Depts
 From 10/1/2025 Through 2/28/2026

00003 - Public Works

GL Code	GL Title	Revised Budget	Increase	Decrease	Amended	Actual	Encumbrance	Available Budget
05101	Salaries	1,227,072.00		(90,000.00)	1,137,072.00	784,042.61	0.00	353,029.39
05103	Overtime	50,000.00			50,000.00	27,281.36	0.00	22,718.64
05111	FICA/Medicare Taxes	103,816.00		(10,000.00)	93,816.00	61,341.14	0.00	32,474.86
05112	T.W.C. Payroll Taxes	9,100.00			9,100.00	2,274.27	0.00	6,825.73
05113	Health Insurance Premiums	308,000.00		(45,000.00)	263,000.00	183,586.88	0.00	79,413.12
05114	Workers Compensation Insurance	75,500.00			75,500.00	29,747.48	0.00	45,752.52
05115	Deferred Compensation Benefits	15,000.00	16,000.00		31,000.00	25,691.95	0.00	5,308.05
05116	Life Insurance	2,154.00			2,154.00	1,728.07	0.00	425.93
05117	Dental Insurance Expense	10,220.00			10,220.00	6,629.91	0.00	3,590.09
05118	Vision Insurance Expense	2,205.00			2,205.00	1,195.50	0.00	1,009.50
05119	Employee Assistance Program	150.00			150.00	0.00	0.00	150.00
05120	FUTA Payroll Taxes	50.00			50.00	0.00	0.00	50.00
05121	Payroll Fees	600.00			600.00	515.42	0.00	84.58
05201	Office Expense and Supplies	9,000.00			9,000.00	7,979.78	0.00	1,020.22
05212	Tools and Supplies	38,000.00			38,000.00	24,023.56	0.00	13,976.44
05213	Uniforms	46,000.00			46,000.00	27,352.38	425.60	18,222.02
05311	Building & Property Maintenance	20,000.00			20,000.00	4,310.57	0.00	15,689.43
05312	Street Maintenance	160,000.00			160,000.00	58,463.70	6,286.00	95,250.30
05313	Utilities	315,000.00			315,000.00	223,624.23	0.00	91,375.77
05314	Telephone	25,000.00			25,000.00	3,377.60	0.00	21,622.40
05317	Park Maintenance	130,000.00			130,000.00	33,723.40	27,319.91	68,956.69
05325	Recycling Center	22,000.00			22,000.00	13,557.98	0.00	8,442.02
05411	Legal Fees	20,000.00			20,000.00	11,532.85	1,061.48	7,405.67
05510	Property Insurance	24,000.00			24,000.00	12,444.98	0.00	11,555.02
05516	Dues/Subscriptions	600.00			600.00	499.70	0.00	100.30
05518	Liability Insurance	22,000.00			22,000.00	18,449.06	0.00	3,550.94
05520	Service Contracts	200,000.00			200,000.00	76,056.67	17,802.30	106,141.03
05521	Support Activities	4,500.00			4,500.00	2,111.97	0.00	2,388.03
05523	Equipment Rental/Lease	20,000.00			20,000.00	922.82	0.00	19,077.18
05527	Seminars/Training/Workshops	7,000.00			7,000.00	550.00	0.00	6,450.00
05610	Office Furniture	500.00			500.00	0.00	0.00	500.00
05611	Radio Communications and Maint	500.00			500.00	0.00	0.00	500.00
05612	Vehicle Repair & Maintenance	20,000.00			20,000.00	13,196.20	0.00	6,803.80
05613	Equipment Repair & Maintenance	52,000.00			52,000.00	25,921.83	0.00	26,078.17

City of Socorro
 Detail Budget/Actual Transactions - LG - Budget Rpt for the Depts
 From 10/1/2025 Through 2/28/2026

05614	Vehicle Fuel	55,000.00		55,000.00	31,896.07	0.00	23,103.93
05711	Travel Lodg Airf Mil	3,000.00		3,000.00	0.00	0.00	3,000.00
05810	Property and Equipment	50,000.00	(35,000.00)	15,000.00	0.00	0.00	15,000.00
05900	Emergency Aid and Assistance	5,000.00		5,000.00	0.00	0.00	5,000.00
08000	Settlements	711.00		711.00	710.10	0.00	0.90
	Balance 00003 - Public Works	3,053,678.00	16,000.00 (180,000.00)	2,889,678.00	1,714,740.04	52,895.29	1,122,042.67

City of Socorro
 Detail Budget/Actual Transactions - LG - Budget Rpt for the Depts
 From 10/1/2025 Through 2/28/2026

00004 - Fire and
 Ambulance

GL Code	GL Title	Revised Budget	Increase	Decrease	Amended	Actual	Encumbrance	Available Budget
05201	Office Expense and Supplies	200.00			200.00	0.00	0.00	200.00
05212	Tools and Supplies	500.00			500.00	0.00	0.00	500.00
05311	Building & Property Maintenanac	4,000.00			4,000.00	1,792.13	0.00	2,207.87
05313	Utilities	23,300.00	6,000.00		29,300.00	26,348.49	0.00	2,951.51
05314	Telephone	1,700.00	2,000.00		3,700.00	2,599.17	0.00	1,100.83
05510	Property Insurance	2,400.00	450.00		2,850.00	2,615.82	0.00	234.18
05518	Liability Insurance	700.00	450.00		1,150.00	941.85	0.00	208.15
05525	Health/Ambulance Contract	246,000.00			246,000.00	122,500.00	0.00	123,500.00
05614	Vehicle Fuel	12,000.00	1,000.00		13,000.00	12,040.78	0.00	959.22
05810	Property and Equipment	4,000.00		(2,000.00)	2,000.00	0.00	0.00	2,000.00
	Balance 00004 - Fire and Ambulance	294,800.00	9,900.00	(2,000.00)	302,700.00	168,838.24	0.00	133,861.76

City of Socorro
 Detail Budget/Actual Transactions - I.G - Budget Rpt for the Depts
 From 10/1/2025 Through 2/28/2026

00005 - Police
 Department

GL Code	GL Title	Revised Budget	Increase	Decrease	Amended	Actual	Encumbrance	Available Budget
05101	Salaries	4,242,094.00			4,242,094.00	2,918,778.72	0.00	1,323,315.28
05103	Overtime	400,000.00			400,000.00	228,250.15	0.00	171,749.85
05111	FICA/Medicare Taxes	361,240.00		(25,000.00)	336,240.00	233,678.19	0.00	102,561.81
05112	T.W.C. Payroll Taxes	18,720.00		(5,000.00)	13,720.00	4,162.08	0.00	9,557.92
05113	Health Insurance Premiums	633,600.00		(50,000.00)	583,600.00	389,931.23	0.00	193,668.77
05114	Workers Compensation Insurance	72,700.00			72,700.00	56,811.34	0.00	15,888.66
05115	Deferred Compensation Benefits	200,000.00			200,000.00	148,937.79	0.00	51,062.21
05116	Life Insurance	6,480.00			6,480.00	6,255.19	0.00	224.81
05117	Dental Insurance Expense	21,024.00			21,024.00	17,374.96	0.00	3,649.04
05118	Vision Insurance Expense	4,536.00			4,536.00	2,594.97	0.00	1,941.03
05120	FUTA Payroll Taxes	60.00			60.00	0.00	0.00	60.00
05121	Payroll Fees	2,000.00	200.00		2,200.00	2,092.44	0.00	107.56
05201	Office Expense and Supplies	35,000.00			35,000.00	13,705.72	0.00	21,294.28
05202	Medical Supplies	500.00			500.00	0.00	0.00	500.00
05211	Postage	5,300.00			5,300.00	583.99	0.00	4,716.01
05212	Tools and Supplies	100,000.00			100,000.00	21,234.70	0.00	78,765.30
05213	Uniforms	33,000.00			33,000.00	15,436.82	0.00	17,563.18
05311	Building & Property Maintenan	17,500.00			17,500.00	5,479.80	0.00	12,020.20
05313	Utilities	90,000.00			90,000.00	59,298.58	0.00	30,701.42
05314	Telephone	40,000.00			40,000.00	15,369.36	0.00	24,630.64
05411	Legal Fees	40,000.00		(10,000.00)	30,000.00	363.12	2,262.40	27,374.48
05510	Property Insurance	30,000.00			30,000.00	22,846.52	0.00	7,153.48
05516	Dues/Subscriptions	14,500.00			14,500.00	6,088.77	0.00	8,411.23
05518	Liability Insurance	90,000.00			90,000.00	69,560.71	0.00	20,439.29
05520	Service Contracts	120,000.00			120,000.00	86,181.95	0.00	33,818.05
05521	Support Activities	12,000.00			12,000.00	6,888.58	0.00	5,111.42
05523	Equipment Rental/Lease	12,000.00			12,000.00	3,583.82	4,506.18	3,910.00
05527	Seminars/Training/Workshops	65,000.00			65,000.00	20,406.00	0.00	44,594.00
05611	Radio Communications and Maint	2,000.00			2,000.00	649.05	0.00	1,350.95
05612	Vehicle Repair & Maintenance	45,000.00	6,000.00		51,000.00	48,507.76	0.00	2,492.24
05613	Equipment Repair & Maintenance	10,000.00			10,000.00	7,026.00	0.00	2,974.00
05614	Vehicle Fuel	80,000.00			80,000.00	55,627.50	0.00	24,372.50
05711	Travel Lodg Airf Mil	33,000.00			33,000.00	16,705.84	0.00	16,294.16
05810	Property and Equipment	50,000.00			50,000.00	43,344.06	0.00	6,655.94

City of Socorro
 Detail Budget/Actual Transactions - LG - Budget Rpt for the Depts
 From 10/1/2025 Through 2/28/2026

08000	Settlements	0.00	200.00		200.00	200.00	0.00	0.00
	Balance 00005 - Police Department	6,887,254.00	6,400.00	(90,000.00)	6,803,654.00	4,527,955.71	6,768.58	2,268,929.71

City of Socorro
 Detail Budget/Actual Transactions - LG - Budget Rpt for the Depts
 From 10/1/2025 Through 2/28/2026

00006 -
 Municipal Court

GL Code	GL Title	Revised Budget	Increase	Decrease	Amended	Actual	Encumbrance	Available Budget
05101	Salaries	190,827.00			190,827.00	129,760.89	0.00	61,066.11
05103	Overtime	8,500.00			8,500.00	2,612.44	0.00	5,887.56
05111	FICA/Medicare Taxes	15,249.00			15,249.00	9,976.14	0.00	5,272.86
05112	T.W.C. Payroll Taxes	1,040.00			1,040.00	266.59	0.00	773.41
05113	Health Insurance Premiums	35,200.00			35,200.00	23,970.96	0.00	11,229.04
05114	Workers Compensation Insurance	585.00			585.00	351.27	0.00	233.73
05115	Deferred Compensation Benefits	500.00			500.00	0.00	0.00	500.00
05116	Life Insurance	384.00			384.00	321.88	0.00	62.12
05117	Dental Insurance Expense	1,168.00			1,168.00	1,046.48	0.00	121.52
05118	Vision Insurance Expense	252.00			252.00	163.62	0.00	88.38
05121	Payroll Fees	120.00			120.00	84.63	0.00	35.37
05201	Office Expense and Supplies	14,000.00			14,000.00	4,431.33	0.00	9,568.67
05211	Postage	3,000.00			3,000.00	502.25	0.00	2,497.75
05213	Uniforms	2,000.00			2,000.00	0.00	0.00	2,000.00
05311	Building & Property Maintenance	5,000.00	10,000.00		15,000.00	14,325.48	0.00	674.52
05313	Utilities	3,000.00			3,000.00	2,525.83	0.00	474.17
05314	Telephone	11,000.00			11,000.00	2,651.04	0.00	8,348.96
05411	Legal Fees	40,000.00		(5,000.00)	35,000.00	17,004.68	576.31	17,419.01
05510	Property Insurance	6,000.00			6,000.00	2,656.49	0.00	3,343.51
05511	Advertising/Drug Testing	7,500.00			7,500.00	0.00	0.00	7,500.00
05516	Dues/Subscriptions	2,000.00			2,000.00	149.90	0.00	1,850.10
05518	Liability Insurance	1,500.00			1,500.00	941.85	0.00	558.15
05520	Service Contracts	75,600.00	100.00		75,700.00	41,625.29	34,036.61	38.10
05521	Support Activities	5,500.00			5,500.00	5,123.20	0.00	376.80
05523	Equipment Rental/Lease	2,000.00			2,000.00	731.79	0.00	1,268.21
05527	Seminars/Training/Workshops	3,800.00			3,800.00	2,528.66	0.00	1,271.34
05610	Office Furniture	3,000.00			3,000.00	1,545.05	0.00	1,454.95
05613	Equipment Repair & Maintenance	800.00			800.00	0.00	0.00	800.00
05711	Travel Lodg Airf Mil	5,600.00			5,600.00	3,592.20	0.00	2,007.80
05810	Property and Equipment	65,000.00			65,000.00	13,352.00	12,279.00	39,369.00
	Balance 00006 - Municipal Court	510,125.00	10,100.00	(5,000.00)	515,225.00	282,241.94	46,891.92	186,091.14

City of Socorro
 Detail Budget/Actual Transactions - LG - Budget Rpt for the Depts
 From 10/1/2025 Through 2/28/2026

00007 - Planning
 and Zoning

GL Code	GL Title	Revised Budget	Increase	Decrease	Amended	Actual	Encumbrance	Available Budget
05101	Salaries	482,811.00		(30,000.00)	452,811.00	310,534.75	0.00	142,276.25
05103	Overtime	8,000.00			8,000.00	6,556.91	0.00	1,443.09
05111	FICA/Medicare Taxes	44,432.00		(8,000.00)	36,432.00	23,875.60	0.00	12,556.40
05112	T.W.C. Payroll Taxes	2,860.00			2,860.00	648.16	0.00	2,211.84
05113	Health Insurance Premiums	96,800.00		(15,000.00)	81,800.00	54,029.15	0.00	27,770.85
05114	Workers Compensation Insurance	2,705.00			2,705.00	1,042.01	0.00	1,662.99
05115	Deferred Compensation Benefits	7,500.00	8,000.00		15,500.00	11,934.47	0.00	3,565.53
05116	Life Insurance	811.00			811.00	472.33	0.00	338.67
05117	Dental Insurance Expense	3,212.00			3,212.00	2,075.40	0.00	1,136.60
05118	Vision Insurance Expense	693.00			693.00	341.06	0.00	351.94
05119	Employee Assistance Program	200.00			200.00	0.00	0.00	200.00
05120	FUTA Payroll Taxes	60.00			60.00	0.00	0.00	60.00
05121	Payroll Fees	250.00			250.00	187.36	0.00	62.64
05201	Office Expense and Supplies	14,000.00			14,000.00	6,533.14	0.00	7,466.86
05211	Postage	5,000.00			5,000.00	2,631.75	0.00	2,368.25
05212	Tools and Supplies	2,300.00			2,300.00	125.89	0.00	2,174.11
05213	Uniforms	3,000.00			3,000.00	2,657.33	0.00	342.67
05311	Building & Property Maintenance	9,000.00		(4,000.00)	5,000.00	995.40	0.00	4,004.60
05313	Utilities	9,000.00			9,000.00	5,581.18	0.00	3,418.82
05314	Telephone	16,000.00			16,000.00	2,688.69	0.00	13,311.31
05411	Legal Fees	72,000.00		(5,000.00)	67,000.00	35,808.20	4,050.38	27,141.42
05510	Property Insurance	2,500.00			2,500.00	318.18	0.00	2,181.82
05511	Advertising/Drug Testing	11,000.00			11,000.00	4,065.34	0.00	6,934.66
05516	Dues/Subscriptions	8,000.00	2,000.00		10,000.00	8,537.66	0.00	1,462.34
05518	Liability Insurance	19,000.00			19,000.00	1,710.38	0.00	17,289.62
05520	Service Contracts	307,000.00			307,000.00	151,563.15	20,892.96	134,543.89
05521	Support Activities	2,000.00			2,000.00	969.67	0.00	1,030.33
05523	Equipment Rental/Lease	12,000.00			12,000.00	9,221.09	0.00	2,778.91
05527	Seminars/Training/Workshops	7,000.00	500.00		7,500.00	7,438.32	0.00	61.68
05610	Office Furniture	1,000.00			1,000.00	938.90	0.00	61.10
05612	Vehicle Repair & Maintenance	2,500.00			2,500.00	2,390.67	0.00	109.33
05613	Equipment Repair & Maintenance	2,000.00			2,000.00	0.00	0.00	2,000.00
05614	Vehicle Fuel	2,500.00			2,500.00	2,291.76	0.00	208.24

City of Socorro
 Detail Budget/Actual Transactions - LG - Budget Rpt for the Depts
 From 10/1/2025 Through 2/28/2026

05711	Travel Lodg Airf Mil	7,500.00			7,500.00	3,333.35	0.00	4,166.65
05810	Property and Equipment	50,000.00		(23,000.00)	27,000.00	2,281.40	0.00	24,718.60
	Balance 00007 - Planning and Zoning	1,214,634.00	10,500.00	(85,000.00)	1,140,134.00	663,778.65	24,943.34	451,412.01

City of Socorro
Detail Budget/Actual Transactions - LG - Budget Rpt for the Depts
From 10/1/2025 Through 2/28/2026

00008 - Health
Department

GL Code	GL Title	Revised Budget	Increase	Decrease	Amended	Actual	Encumbrance	Available Budget
05525	Health/Ambulance Contract	650,000.00			650,000.00	358,363.00	0.00	291,637.00
	Balance 00008 - Health Department	650,000.00	0.00	0.00	650,000.00	358,363.00	0.00	291,637.00

City of Socorro
 Detail Budget/Actual Transactions - LG - Budget Rpt for the Depts
 From 10/1/2025 Through 2/28/2026

00010 - Grants
 and Special
 Projects

GL Code	GL Title	Revised Budget	Increase	Decrease	Amended	Actual	Encumbrance	Available Budget
05101	Salaries	244,085.00			244,085.00	173,427.10	0.00	70,657.90
05103	Overtime	3,000.00			3,000.00	268.16	0.00	2,731.84
05111	FICA/Medicare Taxes	25,022.00			25,022.00	12,726.05	0.00	12,295.95
05112	T.W.C. Payroll Taxes	1,300.00			1,300.00	240.33	0.00	1,059.67
05113	Health Insurance Premiums	44,000.00		(3,000.00)	41,000.00	22,355.27	0.00	18,644.73
05114	Workers Compensation Insurance	689.00			689.00	0.00	0.00	689.00
05115	Deferred Compensation Benefits	6,100.00	6,000.00		12,100.00	9,807.38	0.00	2,292.62
05116	Life Insurance	750.00			750.00	328.52	0.00	421.48
05117	Dental Insurance Expense	1,460.00			1,460.00	915.32	0.00	544.68
05118	Vision Insurance Expense	315.00			315.00	171.97	0.00	143.03
05120	FUTA Payroll Taxes	25.00			25.00	0.00	0.00	25.00
05121	Payroll Fees	200.00			200.00	110.63	0.00	89.37
05201	Office Expense and Supplies	6,500.00			6,500.00	5,519.49	0.00	980.51
05211	Postage	300.00			300.00	0.00	0.00	300.00
05213	Uniforms	600.00			600.00	415.06	0.00	184.94
05314	Telephone	5,000.00			5,000.00	1,860.64	0.00	3,139.36
05411	Legal Fees	5,000.00			5,000.00	810.04	0.00	4,189.96
05511	Advertising/Drug Testing	1,500.00			1,500.00	0.00	0.00	1,500.00
05516	Dues/Subscriptions	3,500.00	600.00		4,100.00	3,889.24	0.00	210.76
05520	Service Contracts	7,500.00			7,500.00	113.50	0.00	7,386.50
05521	Support Activities	5,000.00			5,000.00	1,372.75	0.00	3,627.25
05527	Seminars/Training/Workshops	5,000.00			5,000.00	3,178.00	0.00	1,822.00
05711	Travel Lodg Airf Mil	5,000.00			5,000.00	3,508.56	0.00	1,491.44
05810	Property and Equipment	3,500.00			3,500.00	0.00	0.00	3,500.00
06440	Grant Expense	10,000.00		(5,000.00)	5,000.00	0.00	0.00	5,000.00
	Balance 00010 - Grants and Special Projects	385,346.00	6,600.00	(8,000.00)	383,946.00	241,018.01	0.00	142,927.99

City of Socorro
 Detail Budget/Actual Transactions - I.G - Budget Rpt for the Depts
 From 10/1/2025 Through 2/28/2026

00012 - Human
 Resources

GL Code	GL Title	Revised Budget	Increase	Decrease	Amended	Actual	Encumbrance	Available Budget
05101	Salaries	73,590.00			73,590.00	50,947.20	0.00	22,642.80
05111	FICA/Medicare Taxes	5,630.00			5,630.00	3,847.07	0.00	1,782.93
05112	T.W.C. Payroll Taxes	260.00			260.00	59.04	0.00	200.96
05113	Health Insurance Premiums	8,800.00			8,800.00	5,992.74	0.00	2,807.26
05114	Workers Compensation Insurance	145.00	350.00		495.00	292.82	0.00	202.18
05115	Deferred Compensation Benefits	4,500.00			4,500.00	3,396.45	0.00	1,103.55
05116	Life Insurance	250.00			250.00	101.07	0.00	148.93
05117	Dental Insurance Expense	292.00			292.00	223.56	0.00	68.44
05118	Vision Insurance Expense	63.00			63.00	40.50	0.00	22.50
05119	Employee Assistance Program	5,321.00			5,321.00	5,321.00	0.00	0.00
05121	Payroll Fees	40.00			40.00	24.32	0.00	15.68
05201	Office Expense and Supplies	1,700.00			1,700.00	1,128.44	0.00	571.56
05211	Postage	150.00			150.00	25.04	0.00	124.96
05314	Telephone	800.00	800.00		1,600.00	1,452.17	0.00	147.83
05411	Legal Fees	30,000.00		(5,000.00)	25,000.00	7,322.35	1,648.08	16,029.57
05510	Property Insurance	50.00			50.00	9.06	0.00	40.94
05511	Advertising/Drug Testing	15,000.00			15,000.00	7,956.76	0.00	7,043.24
05516	Dues/Subscriptions	500.00			500.00	334.00	0.00	166.00
05518	Liability Insurance	1,500.00			1,500.00	941.85	0.00	558.15
05520	Service Contracts	11,300.00			11,300.00	4,805.20	279.60	6,215.20
05521	Support Activities	3,000.00			3,000.00	1,238.80	0.00	1,761.20
05526	Human Resources	10,000.00			10,000.00	2,148.80	0.00	7,851.20
05527	Seminars/Training/Workshops	4,200.00			4,200.00	2,970.00	0.00	1,230.00
05613	Equipment Repair & Maintenance	600.00			600.00	0.00	0.00	600.00
05711	Travel Lodg Airf Mil	6,500.00			6,500.00	2,145.21	0.00	4,354.79
05810	Property and Equipment	500.00			500.00	0.00	0.00	500.00
	Balance 00012 - Human Resources	184,691.00	1,150.00	(5,000.00)	180,841.00	102,723.45	1,927.68	76,189.87

City of Socorro
 Detail Budget/Actual Transactions - I.G - Budget Rpt for the Depts
 From 10/1/2025 Through 2/28/2026

00013 - Mayor
 and City Council

GL Code	GL Title	Revised Budget	Increase	Decrease	Amended	Actual	Encumbrance	Available Budget
05101	Salaries	57,022.00		(2,000.00)	55,022.00	38,088.00	0.00	16,934.00
05111	FICA/Medicare Taxes	4,974.00			4,974.00	2,655.70	0.00	2,318.30
05112	T.W.C. Payroll Taxes	1,560.00			1,560.00	367.34	0.00	1,192.66
05113	Health Insurance Premiums	52,800.00		(8,000.00)	44,800.00	18,061.61	0.00	26,738.39
05114	Workers Compensation Insurance	299.00	60.00		359.00	333.76	0.00	25.24
05115	Deferred Compensation Benefits	1,000.00			1,000.00	300.00	0.00	700.00
05116	Life Insurance	210.00			210.00	68.94	0.00	141.06
05117	Dental Insurance Expense	1,752.00			1,752.00	778.81	0.00	973.19
05118	Vision Insurance Expense	378.00			378.00	154.93	0.00	223.07
05121	Payroll Fees	40.00			40.00	24.07	0.00	15.93
05201	Office Expense and Supplies	8,000.00			8,000.00	5,616.09	0.00	2,383.91
05213	Uniforms	3,000.00			3,000.00	1,579.40	0.00	1,420.60
05314	Telephone	3,700.00			3,700.00	2,058.55	0.00	1,641.45
05411	Legal Fees	20,000.00	20,000.00		40,000.00	32,600.35	0.00	7,399.65
05510	Property Insurance	250.00			250.00	9.06	0.00	240.94
05516	Dues/Subscriptions	8,000.00			8,000.00	0.00	0.00	8,000.00
05518	Liability Insurance	2,500.00			2,500.00	941.85	0.00	1,558.15
05521	Support Activities	5,000.00			5,000.00	4,982.12	0.00	17.88
05527	Seminars/Training/Workshops	10,000.00			10,000.00	9,326.25	0.00	673.75
05610	Office Furniture	2,000.00			2,000.00	0.00	0.00	2,000.00
05711	Travel Lodg Airf Mil	21,000.00			21,000.00	13,450.83	0.00	7,549.17
	Balance 00013 - Mayor and City Council	203,485.00	20,060.00	(10,000.00)	213,545.00	131,397.66	0.00	82,147.34

City of Socorro
 Detail Budget/Actual Transactions - LG - Budget Rpt for the Depts
 From 10/1/2025 Through 2/28/2026

00014 - City
 Clerk

GL Code	GL Title	Revised Budget	Increase	Decrease	Amended	Actual	Encumbrance	Available Budget
05101	Salaries	72,213.00			72,213.00	47,678.26	0.00	24,534.74
05111	FICA/Medicare Taxes	5,524.00			5,524.00	3,612.93	0.00	1,911.07
05112	T.W.C. Payroll Taxes	260.00			260.00	59.04	0.00	200.96
05113	Health Insurance Premiums	8,800.00			8,800.00	5,992.74	0.00	2,807.26
05114	Workers Compensation Insurance	288.00	20.00		308.00	292.82	0.00	15.18
05115	Deferred Compensation Benefits	4,500.00			4,500.00	3,178.49	0.00	1,321.51
05116	Life Insurance	150.00			150.00	94.40	0.00	55.60
05117	Dental Insurance Expense	292.00			292.00	223.56	0.00	68.44
05118	Vision Insurance Expense	63.00			63.00	40.50	0.00	22.50
05121	Payroll Fees	40.00			40.00	25.18	0.00	14.82
05201	Office Expense and Supplies	3,000.00			3,000.00	2,062.29	0.00	937.71
05211	Postage	200.00			200.00	121.32	0.00	78.68
05314	Telephone	600.00			600.00	308.97	0.00	291.03
05411	Legal Fees	17,000.00			17,000.00	10,625.44	716.29	5,658.27
05510	Property Insurance	130.00			130.00	9.06	0.00	120.94
05511	Advertising/Drug Testing	20,000.00			20,000.00	11,887.90	0.00	8,112.10
05515	County Elections	105,000.00			105,000.00	47,958.70	0.00	57,041.30
05516	Dues/Subscriptions	700.00			700.00	0.00	0.00	700.00
05518	Liability Insurance	1,500.00			1,500.00	941.85	0.00	558.15
05520	Service Contracts	24,000.00			24,000.00	11,981.77	11,893.77	124.46
05527	Seminars/Training/Workshops	1,500.00			1,500.00	575.00	0.00	925.00
05711	Travel Lodg Airf Mil	3,200.00			3,200.00	1,472.86	0.00	1,727.14
05810	Property and Equipment	5,000.00			5,000.00	0.00	0.00	5,000.00
	Balance 00014 - City Clerk	273,960.00	20.00	0.00	273,980.00	149,143.08	12,610.06	112,226.86

City of Socorro
 Detail Budget/Actual Transactions - LG - Budget Rpt for the Depts
 From 10/1/2025 Through 2/28/2026

00015 - Finance
 Department

GL Code	GL Title	Revised Budget	Increase	Decrease	Amended	Actual	Encumbrance	Available Budget
05101	Salaries	211,245.00			211,245.00	149,192.96	0.00	62,052.04
05103	Overtime	9,000.00			9,000.00	3,787.93	0.00	5,212.07
05111	FICA/Medicare Taxes	16,849.00			16,849.00	10,757.74	0.00	6,091.26
05112	T.W.C. Payroll Taxes	1,040.00			1,040.00	253.15	0.00	786.85
05113	Health Insurance Premiums	35,200.00			35,200.00	30,218.29	0.00	4,981.71
05114	Workers Compensation Insurance	600.00			600.00	292.82	0.00	307.18
05115	Deferred Compensation Benefits	13,000.00			13,000.00	8,442.18	0.00	4,557.82
05116	Life Insurance	400.00	60.00		460.00	442.55	0.00	17.45
05117	Dental Insurance Expense	1,168.00	200.00		1,368.00	1,277.66	0.00	90.34
05118	Vision Insurance Expense	252.00			252.00	200.38	0.00	51.62
05121	Payroll Fees	120.00			120.00	82.07	0.00	37.93
05201	Office Expense and Supplies	7,000.00			7,000.00	4,055.88	516.75	2,427.37
05314	Telephone	570.00			570.00	308.97	0.00	261.03
05411	Legal Fees	30,000.00	8,000.00		38,000.00	33,657.82	726.27	3,615.91
05510	Property Insurance	110.00			110.00	9.06	0.00	100.94
05512	Audit Fees	70,000.00	35,000.00		105,000.00	96,313.40	0.00	8,686.60
05513	Central Appraisal Fees	216,000.00			216,000.00	110,201.49	0.00	105,798.51
05516	Dues/Subscriptions	10,000.00			10,000.00	8,689.11	0.00	1,310.89
05517	Bank Charges	25,000.00			25,000.00	10,936.20	0.00	14,063.80
05518	Liability Insurance	1,500.00			1,500.00	941.85	0.00	558.15
05520	Service Contracts	122,000.00		(30,000.00)	92,000.00	25,931.95	0.00	66,068.05
05522	Tax Collector Fees	70,000.00			70,000.00	16,899.75	0.00	53,100.25
05527	Seminars/Training/Workshops	2,000.00	2,000.00		4,000.00	3,140.00	0.00	860.00
05538	Late Charge	1,500.00			1,500.00	1,424.25	0.00	75.75
05711	Travel Lodg Airf Mil	2,600.00	330.00		2,930.00	2,923.71	0.00	6.29
05810	Property and Equipment	3,000.00			3,000.00	0.00	0.00	3,000.00
	Balance 00015 - Finance Department	850,154.00	45,590.00	(30,000.00)	865,744.00	520,381.17	1,243.02	344,119.81

City of Socorro
 Detail Budget/Actual Transactions - LG - Budget Rpt for the Depts
 From 10/1/2025 Through 2/28/2026

00016 -
 Recreation
 Centers

GL Code	GL Title	Revised Budget	Increase	Decrease	Amended	Actual	Encumbrance	Available Budget
05101	Salaries	244,938.00		(5,000.00)	239,938.00	166,620.01	0.00	73,317.99
05103	Overtime	20,000.00	12,000.00		32,000.00	26,500.06	0.00	5,499.94
05111	FICA/Medicare Taxes	21,415.00			21,415.00	14,637.11	0.00	6,777.89
05112	T.W.C. Payroll Taxes	1,560.00			1,560.00	426.06	0.00	1,133.94
05113	Health Insurance Premiums	52,800.00			52,800.00	43,280.90	0.00	9,519.10
05114	Workers Compensation Insurance	1,790.00	4,000.00		5,790.00	3,957.73	0.00	1,832.27
05115	Deferred Compensation Benefits	7,300.00			7,300.00	3,399.14	0.00	3,900.86
05116	Life Insurance	340.00			340.00	111.55	0.00	228.45
05117	Dental Insurance Expense	1,752.00	230.00		1,982.00	1,862.46	0.00	119.54
05118	Vision Insurance Expense	378.00			378.00	210.41	0.00	167.59
05120	FUTA Payroll Taxes	90.00			90.00	0.00	0.00	90.00
05121	Payroll Fees	200.00			200.00	157.54	0.00	42.46
05201	Office Expense and Supplies	11,000.00			11,000.00	4,825.34	0.00	6,174.66
05212	Tools and Supplies	700.00			700.00	187.68	0.00	512.32
05213	Uniforms	2,219.00			2,219.00	2,218.06	0.00	0.94
05311	Building & Property Maintenance	10,500.00	1,000.00		11,500.00	10,597.63	0.00	902.37
05313	Utilities	40,000.00			40,000.00	37,814.77	0.00	2,185.23
05314	Telephone	18,000.00			18,000.00	4,604.91	0.00	13,395.09
05411	Legal Fees	3,000.00			3,000.00	0.00	0.00	3,000.00
05510	Property Insurance	10,000.00			10,000.00	7,362.95	0.00	2,637.05
05511	Advertising/Drug Testing	16,005.00	3,000.00		19,005.00	17,626.42	0.00	1,378.58
05516	Dues/Subscriptions	3,750.00	2,000.00		5,750.00	5,547.64	0.00	202.36
05518	Liability Insurance	5,300.00	2,000.00		7,300.00	6,666.17	0.00	633.83
05520	Service Contracts	50,000.00	130,000.00		180,000.00	110,500.46	2,279.47	67,220.07
05521	Support Activities	30,000.00			30,000.00	21,881.61	0.00	8,118.39
05523	Equipment Rental/Lease	11,000.00			11,000.00	7,856.99	0.00	3,143.01
05527	Seminars/Training/Workshops	10,000.00			10,000.00	7,419.67	0.00	2,580.33
05548	Events	100,000.00	5,000.00		105,000.00	71,304.19	31,310.00	2,385.81
05612	Vehicle Repair & Maintenance	6,500.00			6,500.00	79.34	0.00	6,420.66
05613	Equipment Repair & Maintenance	1,600.00			1,600.00	0.00	0.00	1,600.00
05614	Vehicle Fuel	5,000.00	1,000.00		6,000.00	5,542.35	0.00	457.65
05711	Travel Lodg Airf Mil	10,000.00			10,000.00	7,604.21	0.00	2,395.79
05810	Property and Equipment	17,000.00			17,000.00	12,481.95	0.00	4,518.05

City of Socorro
Detail Budget/Actual Transactions - LG - Budget Rpt for the Depts
From 10/1/2025 Through 2/28/2026

Balance 00016 - Recreation Centers	714,137.00	160,230.00	(5,000.00)	869,367.00	603,285.31	33,589.47	232,492.22
------------------------------------	------------	------------	------------	------------	------------	-----------	------------

City of Socorro
 Detail Budget/Actual Transactions - I.G - Budget Rpt for the Depts
 From 10/1/2025 Through 2/28/2026

00025 -
 Information
 Technology

GL Code	GL Title	Revised Budget	Increase	Decrease	Amended	Actual	Encumbrance	Available Budget
05101	Salaries	157,394.00		(15,000.00)	142,394.00	98,360.20	0.00	44,033.80
05103	Overtime	4,000.00	4,000.00		8,000.00	5,429.93	0.00	2,570.07
05111	FICA/Medicare Taxes	12,347.00			12,347.00	7,885.79	0.00	4,461.21
05112	T.W.C. Payroll Taxes	780.00			780.00	190.74	0.00	589.26
05113	Health Insurance Premiums	26,400.00		(3,000.00)	23,400.00	15,980.64	0.00	7,419.36
05114	Workers Compensation Insurance	345.00			345.00	292.82	0.00	52.18
05115	Deferred Compensation Benefits	2,500.00			2,500.00	1,800.00	0.00	700.00
05116	Life Insurance	247.00			247.00	212.53	0.00	34.47
05117	Dental Insurance Expense	876.00			876.00	596.16	0.00	279.84
05118	Vision Insurance Expense	189.00			189.00	112.50	0.00	76.50
05121	Payroll Fees	150.00			150.00	66.33	0.00	83.67
05201	Office Expense and Supplies	15,000.00			15,000.00	9,410.67	0.00	5,589.33
05212	Tools and Supplies	13,500.00			13,500.00	5,754.08	0.00	7,745.92
05213	Uniforms	4,500.00			4,500.00	0.00	0.00	4,500.00
05311	Building & Property Maintenance	3,600.00	400.00		4,000.00	3,808.38	0.00	191.62
05313	Utilities	0.00	30,000.00		30,000.00	19,266.72	0.00	10,733.28
05314	Telephone	2,200.00	17,000.00		19,200.00	13,158.24	0.00	6,041.76
05510	Property Insurance	500.00	50.00		550.00	535.25	0.00	14.75
05516	Dues/Subscriptions	5,000.00	4,000.00		9,000.00	8,474.78	0.00	525.22
05518	Liability Insurance	3,500.00			3,500.00	3,336.27	0.00	163.73
05520	Service Contracts	190,000.00	40,000.00		230,000.00	196,168.08	13,454.00	20,377.92
05521	Support Activities	1,000.00			1,000.00	0.00	0.00	1,000.00
05527	Seminars/Training/Workshops	6,500.00			6,500.00	1,797.00	0.00	4,703.00
05612	Vehicle Repair & Maintenance	5,000.00			5,000.00	2,201.85	0.00	2,798.15
05613	Equipment Repair & Maintenance	3,500.00			3,500.00	704.52	0.00	2,795.48
05614	Vehicle Fuel	1,000.00			1,000.00	745.39	0.00	254.61
05711	Travel Lodg Airf Mil	6,000.00			6,000.00	280.00	0.00	5,720.00
05810	Property and Equipment	50,000.00		(15,000.00)	35,000.00	22,731.36	0.00	12,268.64
	Balance 00025 - Information Technology	516,028.00	95,450.00	(33,000.00)	578,478.00	419,300.23	13,454.00	145,723.77

City of Socorro
 Detail Budget/Actual Transactions - LG - Budget Rpt for the Depts
 From 10/1/2025 Through 2/28/2026

00026 - Transit
 Services

GL Code	GL Title	Revised Budget	Increase	Decrease	Amended	Actual	Encumbrance	Available Budget
05101	Salaries	52,400.00			52,400.00	37,846.21	0.00	14,553.79
05103	Overtime	20,000.00			20,000.00	4,294.81	0.00	15,705.19
05111	FICA/Medicare Taxes	6,304.00			6,304.00	3,223.78	0.00	3,080.22
05112	T.W.C. Payroll Taxes	520.00			520.00	245.90	0.00	274.10
05113	Health Insurance Premiums	17,600.00		(5,000.00)	12,600.00	7,990.32	0.00	4,609.68
05114	Workers Compensation Insurance	400.00			400.00	0.00	0.00	400.00
05115	Deferred Compensation Benefits	3,000.00			3,000.00	915.00	0.00	2,085.00
05116	Life Insurance	172.00	250.00		422.00	315.94	0.00	106.06
05117	Dental Insurance Expense	584.00			584.00	298.08	0.00	285.92
05118	Vision Insurance Expense	126.00			126.00	0.00	0.00	126.00
05120	FUTA Payroll Taxes	60.00			60.00	0.00	0.00	60.00
05121	Payroll Fees	40.00			40.00	27.58	0.00	12.42
05201	Office Expense and Supplies	2,000.00			2,000.00	1,459.15	0.00	540.85
05212	Tools and Supplies	1,500.00			1,500.00	0.00	0.00	1,500.00
05213	Uniforms	2,000.00			2,000.00	1,320.33	0.00	679.67
05313	Utilities	2,000.00		(1,000.00)	1,000.00	0.00	0.00	1,000.00
05314	Telephone	5,000.00		(2,000.00)	3,000.00	0.00	0.00	3,000.00
05411	Legal Fees	10,000.00			10,000.00	1,005.51	0.00	8,994.49
05510	Property Insurance	5,000.00			5,000.00	0.00	0.00	5,000.00
05516	Dues/Subscriptions	6,000.00	5,000.00		11,000.00	9,236.93	0.00	1,763.07
05518	Liability Insurance	5,000.00		(2,000.00)	3,000.00	0.00	0.00	3,000.00
05520	Service Contracts	5,000.00	2,000.00		7,000.00	5,981.63	0.00	1,018.37
05523	Equipment Rental/Lease	10,000.00		(3,000.00)	7,000.00	150.97	0.00	6,849.03
05527	Seminars/Training/Workshops	2,000.00			2,000.00	1,625.71	0.00	374.29
05610	Office Furniture	1,000.00			1,000.00	0.00	0.00	1,000.00
05611	Radio Communications and Maint	3,000.00			3,000.00	1,365.00	0.00	1,635.00
05612	Vehicle Repair & Maintenance	2,500.00			2,500.00	1,687.47	0.00	812.53
05613	Equipment Repair & Maintenance	1,500.00			1,500.00	90.16	0.00	1,409.84
05614	Vehicle Fuel	48,000.00		(20,000.00)	28,000.00	1,159.47	0.00	26,840.53
05711	Travel Lodg Airf Mil	2,000.00			2,000.00	425.80	0.00	1,574.20
	Balance 00026 - Transit Services	214,706.00	7,250.00	(33,000.00)	188,956.00	80,665.75	0.00	108,290.25

City of Socorro
 Detail Budget/Actual Transactions - LG - Budget Rpt for the Depts
 From 10/1/2025 Through 2/28/2026

00027 - Custodial
 Services

GL Code	GL Title	Revised Budget	Increase	Decrease	Amended	Actual	Encumbrance	Available Budget
05101	Salaries	2,852,158.00			2,852,158.00	0.00	0.00	2,852,158.00
05111	FICA/Medicare Taxes	218,190.00			218,190.00	0.00	0.00	218,190.00
05112	T.W.C. Payroll Taxes	20,020.00			20,020.00	0.00	0.00	20,020.00
05113	Health Insurance Premiums	677,600.00			677,600.00	0.00	0.00	677,600.00
05114	Workers Compensation Insurance	169,400.00			169,400.00	0.00	0.00	169,400.00
05116	Life Insurance	18,711.00			18,711.00	0.00	0.00	18,711.00
05117	Dental Insurance Expense	22,484.00			22,484.00	0.00	0.00	22,484.00
05118	Vision Insurance Expense	4,851.00			4,851.00	0.00	0.00	4,851.00
05201	Office Expense and Supplies	5,000.00			5,000.00	0.00	0.00	5,000.00
05212	Tools and Supplies	700,000.00			700,000.00	0.00	0.00	700,000.00
05213	Uniforms	20,000.00			20,000.00	9,815.50	0.00	10,184.50
05411	Legal Fees	10,000.00			10,000.00	0.00	0.00	10,000.00
	Balance 00027 - Custodial Services	4,718,414.00	0.00	0.00	4,718,414.00	9,815.50	0.00	4,708,598.50
Report Transaction Totals		22,917,803.00	541,730.00	(542,000.00)	22,917,533.00	11,511,645.79	419,042.75	10,986,844.46

DEPARTMENT	GL CODE DESCRIPTION	INCREASE AMOUNT	DECREASE AMOUNT	EXPLANATION
CITY MANAGER	Health Premiums	0.00	-10,000.00	will not use this fiscal year
	Workers Compensation	0.00	-5,000.00	will not use this fiscal year
	Deferred Compensation	10,000.00	0.00	increased participation
	Life Insurance	80.00	0.00	adjustment due to age
	Dental Insurance	400.00	0.00	under budgeted
	Utilities	16,000.00	0.00	moving to telephone line item
	Telephone	0.00	-16,000.00	decreaing used in utilities
	Legal Fees	0.00	-5,000.00	will not use this fiscal year
	Service Contracts	126,000.00	0.00	
	Property and Equipment	0.00	-20,000.00	will not use this fiscal year
		152,480.00	-56,000.00	TOTALS
PUBLIC WORKS	Salaries	0.00	-90,000.00	due to vacancies
	FICA	0.00	-10,000.00	due to vacanices
	Health Premiums	0.00	-45,000.00	due to vacancies
	Deferred Compensation	16,000.00	0.00	increased participation
	Property and Equipment	0.00	-35,000.00	will not use this fiscal year
		0.00	0.00	
		16,000.00	-180,000.00	TOTALS
FIRE AND AMBULANCE	Utilities	6,000.00	0.00	not budgeted for this department
	Telephone	2,000.00	0.00	not budgeted for this department
	Property Insurance	450.00	0.00	not budgeted for this department
	Liability Insurance	450.00	0.00	not budgeted for this department
	Vehicle Fuel	1,000.00	0.00	increase in pricing
	Property and Equipment	0.00	-2,000.00	will not use this fiscal year
		0.00	0.00	
		9,900.00	-2,000.00	TOTALS

POLICE DEPARTMENT	FICA	0.00	-25,000.00	due to vacancies
	T.W.C. Payroll Taxes	0.00	-5,000.00	due to vacancies
	Health Premiums	0.00	-50,000.00	due to vacancies
	Payroll Fees	200.00	0.00	paycom fees
	Legal Fees	0.00	-10,000.00	will not use this fiscal year
	Vehicle Repair and Maintenance	6,000.00	0.00	increase in maintenance
	Settlements	200.00	0.00	damages
		6,400.00	-90,000.00	TOTALS
MUNICIPAL COURT	Building Property Maintenance	10,000.00	0.00	floors
	Legal Fees	0.00	-5,000.00	will not use this fiscal year
	Service Contracts	100.00	0.00	adjustment needed
		0.00	0.00	
		10,100.00	-5,000.00	
PLANNING & ZONING	Salaries	0.00	-30,000.00	due to vacancies
	FICA	0.00	-8,000.00	due to vacancies
	Health Premiums	0.00	-15,000.00	due to vacancies
	Deferred Compensation	8,000.00	0.00	increased participation
	Building Property Maintenance	0.00	-4,000.00	will not use this fiscal year
	Legal Fees	0.00	-5,000.00	will not use this fiscal year
	Dues and Subscriptions	2,000.00	0.00	adjustment needed
	Seminars Training Workshops	500.00	0.00	staff attending trainings
	Property and Equipment	0.00	-23,000.00	will not use this fiscal year
		10,500.00	-85,000.00	TOTALS
GRANTS & SPECIAL PROJ.	Health Premiums	0.00	-3,000.00	due to vacancies
	Deferred Compensation	6,000.00	0.00	increased participation
	Dues and Subscriptions	600.00	0.00	adjustment needed
	Grant Expense	0.00	-5,000.00	will not use this fiscal year
		6,600.00	-8,000.00	TOTALS
HUMAN RESOURCES	Workers Compensation	350.00	0.00	adjustment needed
	Telephone	800.00	0.00	adjustment needed
	Legal Fees	0.00	-5,000.00	will not use this fiscal year
		0.00	0.00	
		0.00	0.00	
		1,150.00	-5,000.00	
MAYOR & CITY COUNCIL	Salaries	0.00	-2,000.00	will not use this fiscal year
	Health Premiums	0.00	-8,000.00	will not use this fiscal year
	Workers Compensation	60.00	0.00	adjustment needed
	Legal Fees	20,000.00	0.00	adjustment needed
		0.00	0.00	
		20,060.00	-10,000.00	
CITY CLERK	Workers Compensation	20.00	0.00	adjustment needed

		0.00	0.00	
		20.00	0.00	
FINANCE	Life Insurance	60.00	0.00	adjustment due to age
	Dental Insurance	200.00	0.00	adjustment needed
	Legal Fees	8,000.00	0.00	adjustment needed
	Audit Fees	35,000.00	0.00	Audit Fees Increased / Single Audit
	Service Contracts	0.00	-30,000.00	will not use this fiscal year
	Seminars Training Workshops	2,000.00	0.00	adjustment needed
	Travel Lodge Airf Mil	330.00	0.00	adjustment needed
		45,590.00	-30,000.00	TOTALS
RECREATION CENTERS	Salaries	0.00	-5,000.00	due to vacancies
	Overtime	12,000.00	0.00	due to vacancies and high participation
	Workers Compensation	4,000.00	0.00	due to transit services
	Dental Insurance	230.00	0.00	adjustment
	Building and Property Maintenance	1,000.00	0.00	adjustment for fiscal year expenses
	Advertising /Drug Testing	3,000.00	0.00	adjustment for advertising overages
	Dues Subscriptions	2,000.00	0.00	adjustment needed
	Liability Insurance	2,000.00	0.00	adjustment needed
	Service Contracts	130,000.00	0.00	Trenor
	Events	5,000.00	0.00	events
	Vehicle Fuel	1,000.00	0.00	transit
		0.00	0.00	
		160,230.00	-5,000.00	
INFORMATION TECH	Salaries	0.00	-15,000.00	due to vacancies
	Overtime	4,000.00	0.00	due to vacancies
	Health Premiums	0.00	-3,000.00	due to vacancies
	Building and Property Maintenance	400.00	0.00	adjustment needed
	Utilities	30,000.00	0.00	adjustment needed
	Telephone	17,000.00	0.00	adjustment needed
	Property Insurance	50.00	0.00	adjustment needed
	Dues and Subscriptions	4,000.00	0.00	adjustment needed
	Service Contracts	40,000.00	0.00	adjustment needed server upgrade
	Property and Equipment	0.00	-15,000.00	will not use this fiscal year
		0.00	0.00	
		95,450.00	-33,000.00	
TRANSIT SERVICES	Health Premiums	0.00	-5,000.00	will not use this fiscal year
	Life Insurance	250.00	0.00	adjustment needed due to age
	Utilities	0.00	-1,000.00	paycom fees
	Telephone	0.00	-2,000.00	new subscription
	Dues and Subscriptions	5,000.00	0.00	adjustment needed
	Liability Insurance	0.00	-2,000.00	will not use this fiscal year

	Service Contracts	2,000.00	0.00	adjustment needed
	Equipment Rental Lease	0.00	-3,000.00	will not use this fiscal year
	Vehicle Fuel	0.00	-20,000.00	will not use this fiscal year
		7,250.00	-33,000.00	TOTALS
		541,730.00	-542,000.00	Decrease \$270.00

Rudy Cruz Jr.
Mayor

Ruben Reyes
At Large

Cesar Nevarez
District 1



Alejandro Garcia
District 2

Maria "Gina" Cordero
District 3 / Mayor Pro Tem

Irene Rojas
District 4

Adriana Rodarte
City Manager

TO: MAYOR AND CITY COUNCIL MEMBERS

FROM: Alejandra Valadez, City Development Director

SUBJECT:

Discussion and action to approve Resolution 845 authorizing the submission of a grant application to the Texas Parks and Wildlife Department (TPWD) Local Park Grants Program for the Socorro Parks Improvements Phase I Project, and to authorize a required 50 percent local match.

SUMMARY

City Council will consider approving a Resolution for the submission of a grant application to the Texas Parks and Wildlife Department (TPWD) Local Park Grants Program for the Socorro Parks Improvements Phase I Project. The program provides funding for park acquisition and development projects, and requires a 50 percent local matching contribution.

Approval of this item will authorize the City of Socorro to submit the application, execute all necessary documents, and implement the project if funding is awarded including committing the required local match.

STATEMENT OF THE ISSUE

The Texas Parks and Wildlife Department (TPWD) Local Park Grants Program provides matching grants to eligible local governments for the acquisition, development, and improvement of public parkland and recreational facilities.

The proposed project will focus on necessary improvements to three (3) City parks to enhance accessibility, increase the quality of existing amenities, and address community recreational needs. The proposed project will target the following City parks:

- **Amistad Park** – Neighborhood park serving Gran Valle Subdivision residents within a 15-minute walkshed from this park
- **Callisto Park** - Neighborhood park serving Las Lunas Subdivision residents within a 10-minute walkshed from this park

- **Jardin de Flores Park** - Community park serving Jardin de Flores Unit I residents within a 10-minute walkshed from this park, and 5-minute driveshed from this park

Improvements will include ADA-accessible parking and play-areas, existing playground upgrades, additional shade structures, walking trails, and athletic play-areas. These improvements are intended to provide safe, accessible, and high-quality recreational spaces for residents while supporting community health, wellness, and quality of life.

In accordance with the City's policies, City Council approval is required for grant applications involving local matching funds. The TPWD grant requires a 50 percent match, which obligates the City to provide local funding equal to the grant award amount.

Matching funds for this project were budgeted as part of the Certificates of Obligation approved in 2026 for capital projects within the City of Socorro.

City Council approval is requested to authorize submission of the application and approval of the associated Resolution outlining the City's commitment as required under the grant program.

FINANCIAL IMPACT

Account Code (GF/GL/Dept): 26CO

Funding Source: 2026 Certificates of Obligation

Amount: Up to \$750,000.00

Quotes (Name/Commodity/Price): N/A

Co-op Agreement (Name/Contract#): N/A

ALTERNATIVE

Not Approve – City Council **will not** approve a Resolution authorizing the submission of a grant application to the Texas Parks and Wildlife Department (TPWD) Local Park Grants Program for the Socorro Parks Improvements Phase I Project, and to authorize a required 50 percent local match.

STAFF RECOMMENDATION

APPROVE – City Council **WILL** approve a Resolution authorizing the submission of a grant application to the Texas Parks and Wildlife Department (TPWD) Local Park Grants

Program for the Socorro Parks Improvements Phase I Project, and to authorize a required 50 percent local match.

REQUIRED AUTHORIZATION

1. City Manager _____ Date _____
2. CFO _____ Date _____
3. Attorney _____ Date _____

Rudy Cruz Jr.
Mayor

Ruben Reyes
At Large

Cesar Nevarez
District 1 / Mayor Pro Tem



Alejandro Garcia
District 2

Gina Cordero
District 3

Irene Rojas
District 4

Adriana Rodarte
City Manager

Resolution 845

Local Park Grant Program

Resolution Authorizing Application

A resolution of the City of Socorro, Texas as hereinafter referred to as “Applicant,” designating certain officials as being responsible for, acting for, and on behalf of the Applicant in dealing with the Texas Parks & Wildlife Department, hereinafter referred to as “Department,” for the purpose of participating in the Local Park Grant Program, hereinafter referred to as the “Program”; certifying that the Applicant is eligible to receive program assistance; certifying that the Applicant matching share is readily available; and dedicating the proposed site for permanent (or for the term of the lease for leased property) public park and recreational uses.

WHEREAS, the Applicant is fully eligible to receive assistance under the Program; and

WHEREAS, the Applicant is desirous of authorizing an official to represent and act for the Applicant in dealing with the Department concerning the Program;

BE IT RESOLVED BY THE APPLICANT:

SECTION 1: That the Applicant hereby certifies that they are eligible to receive assistance under the Program, and that notice of the application has been posted according to local public hearing requirements.

SECTION 2: That the Applicant hereby certifies that the matching share for this application is readily available at this time.

SECTION 3: That the Applicant hereby authorizes and directs the City Manager, to act for the Applicant in dealing with the Department for the purposes of the Program, and that the City Manager is hereby officially designated as the representative in this regard.

SECTION 4: The Applicant hereby specifically authorizes the official to make application to the Department concerning the site to be known as Socorro Parks Improvements Phase I in the City of Socorro, Texas for use as a park site and is hereby dedicated (or will be dedicated upon completion of the proposed acquisition) for public park and recreation purposes in perpetuity (or for the lease term, if legal control is through a lease). Projects with federal monies may have differing requirements.

Introduced, read and passed by an affirmative vote of the “Applicant” on this 2nd day of July, 2026.

CITY OF SOCORRO

ATTEST:

Rudy Cruz, Jr., Mayor

Olivia Navarro, City Clerk



AMISTAD PARK



Amistad Park

Amistad Park is 2.1-acre neighborhood park located at 11540 Valle Palomar Road, in the southwestern part of Socorro, TX. Amistad Park includes the existing improvements detailed below:

- Soccer field
- Basketball court
- Walking trail
- Trash receptacle
- Open play area with a playground
- Various landscape trees

The proposed conceptual design aims to upgrade parking areas, upgrade the existing walking trail, include a park entrance, and upgrade existing fields. The proposed improvements at the park include:

- Parking lot design with ADA parking
- Asphalt walking trail
- New playground equipment
- Park entrance pergola
- Food truck parking
- New bleachers

The plans below show the proposed improvements. An opinion of probable construction cost is shown in Appendix A of this report.

SOCORRO PARKS

CITY SOCORRO Tx.



GREENWAY
STUDIO

OPINION OF PROBABLE COST

95% CONCEPTUAL DESIGN PHASE

DATE: JUNE 05, 2024

NO. 2023040

AMISTAD PARK IMPROVEMENTS

ITEM	ITEM DESCRIPTION	UNIT	PROJECTED QUANTITY	ESTIMATED UNIT PRICE	TOTAL
SELECTIVE DEMOLITION					
1	Existing chainlink fence removal and disposal	LF	250	\$15.00	\$3,750.00
2	Dissassemble and return existing 5-12 year playground structure	LS	1	\$6,000.00	\$6,000.00
3	Removal and disposal of existing grass	SF	10,155	\$0.60	\$6,093.00
4	Removal and disposal of existing soccer goal	EA	2	\$1,200.00	\$2,400.00
5	Removal and disposal of existing Aluminum Bleacher	EA	2	\$1,500.00	\$3,000.00
6	Removal and disposal of existing Tree	EA	4	\$800.00	\$3,200.00
7	Fabric replacement for existing Shade Canopy (10' x 40')	LS	1	\$2,500.00	\$2,500.00
8	Swing Frame Touch-Up and Paint Removal	LS	2	\$2,000.00	\$4,000.00
HARDSCAPE					
9	Provide and install 2 1/2 Ft Rock Wall	LF	537	\$35.00	\$18,795.00
10	Provide and install CMU Block Wall (Stucco)	LF	230	\$50.00	\$11,500.00
11	Provide and install Standard Concrete Paving	SF	3,290	\$4.50	\$14,805.00
12	Provide and install 6" Concrete Curb Mowstrip	LF	3,450	\$12.00	\$41,400.00
13	Sport Court Textured Arcylic Surfacer	SF	3,365	\$1.75	\$5,888.75
14	Provide and install Screenings, 3" depth with weed fabric underlayment	SF	8,390	\$1.00	\$8,390.00
15	Provide and install Rock Mulch, 3" depth with weed fabric underlayment	SF	13,115	\$1.50	\$19,672.50
16	Provide and install Playground concrete ramp	EA	2	\$1,500.00	\$3,000.00
17	Provide and install Engineered Wood Fibers (12" Compacted Depth)	SF	7,650	\$6.00	\$45,900.00
SITE FURNITURE					
18	Provide and install 6' Bench	EA	8	\$3,500.00	\$28,000.00
19	Provide and install Trash Receptacle	EA	2	\$2,500.00	\$5,000.00
20	Provide and install Bike Rack	EA	2	\$1,500.00	\$3,000.00
21	Provide and install Park Rules Sign	EA	2	\$900.00	\$1,800.00
22	Provide and install Flood Warning Sign	EA	2	\$600.00	\$1,200.00
23	Provide and install Pergola (Mission/Adobe Architecture)	EA	2	\$8,000.00	\$16,000.00
PLAYGROUND & SPORT EQUIPMENT					
24	Provide and install 5-12 yrs Playground Structure	LS	1	\$50,000.00	\$50,000.00
25	Provide and install Belt Seat (existing swing frame)	EA	4	\$290.00	\$1,160.00
26	Provide and install Full Bucket Seat (existing swing frame)	EA	4	\$800.00	\$3,200.00
27	Provide and install Molded Bucket Seat 2-5 yrs (existing swing frame)	EA	2	\$1,800.00	\$3,600.00
28	Provide and install Molded Bucket Seat 5-12 yrs (existing swing frame)	EA	2	\$1,800.00	\$3,600.00
29	Provide and install Soccer Goal	EA	2	\$6,000.00	\$12,000.00
30	Provide and install Aluminum Bleacher	EA	2	\$3,880.00	\$7,760.00
PLANTING					
31	Trees (2" cal.)	EA	26	\$380.00	\$9,880.00
32	5 gal. shrubs	EA	200	\$30.00	\$6,000.00
33	Automatic Irrigation System	LS	1	\$40,000.00	\$40,000.00
SUBTOTAL					\$392,494.25



JARDIN DE FLORES PARK



Jardin de Flores Park

Jardin de Flores Park is 10.1-acre regional community park located at 253 Flor Margarita Boulevard, Socorro, TX. Jardin de Flores Park includes the existing improvements detailed below:

- Existing irrigation
- Two enclosed playground areas, not shades
- Four shaded bench/picnic areas

The proposed conceptual design aims to provide more activity courts, provide more shading options, and improve illumination. The proposed improvements at the park include:

- Asphalt walking trail
- Flood warning signs
- New playground equipment
- Outdoor exercise equipment
- Improved landscaping area (xeriscape)
- Added benches
- Two canopies
- Bike racks
- Soccer fields
- Addition of trees
- Grilling areas

The plans below show the proposed improvements. An opinion of probable construction cost is shown in Appendix A of this report.

JARDIN DE FLORES PARK IMPROVEMENTS

ITEM	ITEM DESCRIPTION	UNIT	PROJECTED QUANTITY	ESTIMATED UNIT PRICE	TOTAL
SELECTIVE DEMOLITION					
1	Removal and disposal of existing grass	SF	54,710	\$0.60	\$32,826.00
HARDSCAPE					
2	Provide and install Standard Concrete Paving	SF	920	\$4.50	\$4,140.00
3	Provide and install 6" Concrete Curb Mowstrip	LF	2,920	\$12.00	\$35,040.00
4	Provide and install Screenings, 3" depth with weed fabric underlayment	SF	4,000	\$1.00	\$4,000.00
5	Provide and install Rock Mulch, 3" depth with weed fabric underlayment	SF	45,320	\$1.50	\$67,980.00
6	Provide and install Rip Rap Rock, 6" depth with weed fabric underlayment	SF	1,250	\$1.50	\$1,875.00
7	Provide and install Poured-in-place Rubber Surfacing	SF	480	\$14.00	\$6,720.00
8	Provide and install Engineered Wood Fibers (12" Compacted Depth)	SF	6,210	\$6.00	\$37,260.00
SITE FURNITURE					
9	Provide and install Picnic Table (3 Seats)	EA	2	\$6,000.00	\$12,000.00
10	Provide and install Outdoor Grill	EA	2	\$1,000.00	\$2,000.00
11	Provide and install 6' Bench	EA	10	\$3,500.00	\$35,000.00
12	Provide and install Trash Receptacle	EA	2	\$2,500.00	\$5,000.00
13	Provide and install Bike Rack	EA	2	\$1,500.00	\$3,000.00
14	Provide and install Park Rules Sign	EA	2	\$900.00	\$1,800.00
15	Provide and install Flood Warning Sign	EA	3	\$600.00	\$1,800.00
16	Provide and install Exersice Equipment	LS	1	\$36,000.00	\$36,000.00
17	Provide and install 42' x 54' Steel Canopy	EA	2	\$50,000.00	\$100,000.00
PLANTING					
18	Trees (2" cal.)	EA	47	\$380.00	\$17,860.00
19	5 gal. shrubs	EA	300	\$30.00	\$9,000.00
20	Automatic Irrigation System	LS	1	\$10,000.00	\$10,000.00
SUBTOTAL					\$423,301.00

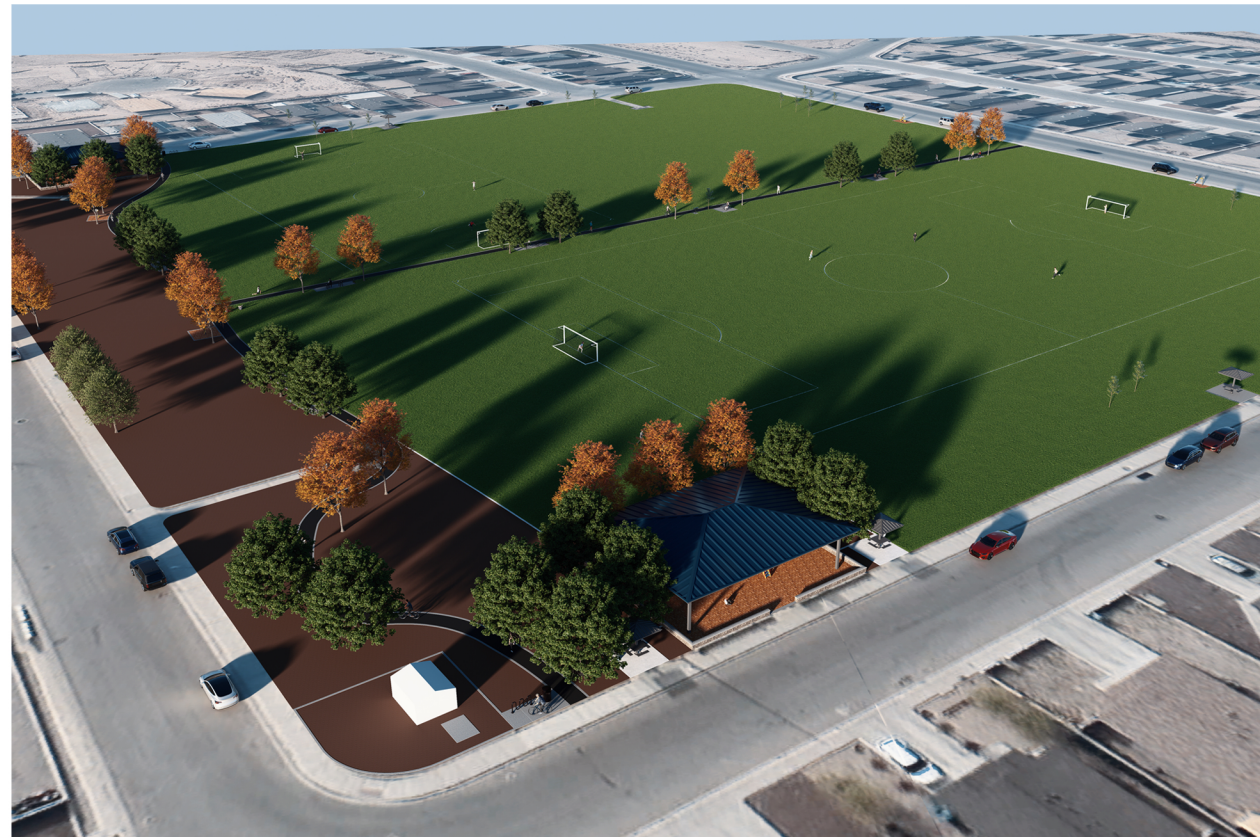

CALLISTO PARK



Callisto Park

Callisto Park is 3.3-acre neighborhood park located at 1034 Callisto Court, Socorro, TX. Callisto Park includes the existing improvements detailed below:

- Existing irrigation system
- Two playground equipment with no shade
- Three picnic areas with shade
- Various landscape trees

The proposed conceptual design aims to provide more activities courts and provide a natural buffer between tiers. The proposed improvements at the park include:

- Futsal court
- Pickleball court
- Turf area
- Sand volleyball court
- Outdoor exercise equipment
- Walking trail

The plans below show the proposed improvements. An opinion of probable construction cost is shown in Appendix A of this report.

CALLISTO PARK IMPROVEMENTS

ITEM	ITEM DESCRIPTION	UNIT	PROJECTED QUANTITY	ESTIMATED UNIT PRICE	TOTAL
SELECTIVE DEMOLITION					
1	Removal and Disposal of Existing Vegetation, Soil, and/or Rock Mulch	SF	61,085	\$0.60	\$36,651.00
HARDSCAPE					
2	Provide and install Concrete Edging for Volleyball Sand Court	LF	285	\$24.90	\$7,096.50
3	Provide and install Concrete Edging	LF	1,740	\$15.00	\$26,100.00
4	Provide and install Fine Play Sand (1ft dept)	SF	5,045	\$0.90	\$4,540.50
5	Provide and install Standard Concrete Paving	SF	4,425	\$6.00	\$26,550.00
6	Provide and install Post-tensioned Concrete Slab	SF	5,981	\$9.00	\$53,829.00
7	Provide and install Sport Court Textured Acrylic Surfacers (Color and Stiping)	LS	8,730	\$2.20	\$19,206.00
8	Provide and install Screenings, 3" depth with weed fabric underlayment	SF	17,470	\$1.25	\$21,837.50
9	Provide and install Rock Mulch, 4" depth with weed fabric underlayment	SF	21,405	\$1.60	\$34,248.00
10	Provide and install Poured in Place Rubber Surfacing	SF	1,500	\$14.00	\$21,000.00
11	Provide and install Futsal Fencing	LS	1	\$22,000.00	\$22,000.00
12	Provide and install Jogging Path Pavement	SF	4,605	\$4.00	\$18,420.00
SITE FURNITURE					
13	Provide and install 6' bench	EA	6	\$3,500.00	\$21,000.00
14	Provide and install shaded picnic table	EA	2	\$16,000.00	\$32,000.00
15	Provide and install trash receptacle	EA	2	\$2,500.00	\$5,000.00
16	Provide and install Bike Rack	EA	3	\$1,500.00	\$4,500.00
17	Provide and install Park Rules Sign	EA	2	\$900.00	\$1,800.00
18	Provide and install Flood Warning Sign	EA	2	\$600.00	\$1,200.00
PLAYGROUND & SPORT EQUIPMENT					
19	Provide and install Healthbeat Fitness Equipment	LS	1	\$63,000.00	\$63,000.00
20	Provide and install Pickleball Post and Net	LS	1	\$1,800.00	\$1,800.00
21	Provide and install Volleyball Post System	LS	1	\$3,600.00	\$3,600.00
PLANTING					
22	Provide and install Trees (2" cal.)	EA	31	\$380.00	\$11,780.00
23	5 gal. shrubs	EA	200	\$30.00	\$6,000.00
IRRIGATION					
24	Provide and install Irrigation System	LS	1	\$25,000.00	\$25,000.00
SUBTOTAL					\$468,158.50



Rudy Cruz, Jr.
Mayor

Ruben Reyes
Representative
At Large

Cesar Nevarez
District 1



Alejandro Garcia
District 2

Gina Cordero
District 3 / Mayor Pro Tem

Irene Rojas
District 4

Adriana Rodarte
City Manager

DATE: July, 2, 2026

TO: Mayor & Council

CC: Adriana Rodarte, City Manager

FROM: Lorraine Quimiro, City Planner Development Director

SUBJECT: Discussion & Action to approve resolution 846 authorizing Mayor to sign the City Pride Sign Agreement between the State of Texas and the City of Socorro, to participate in the Texas Department of Transportation City Pride Sign Program.

SUMMARY

The City Pride Sign Program administered by the Texas Department of Transportation (TxDOT) requires participating municipalities to enter into a City Pride Sign Agreement for the construction or reconstruction of City Pride Signs within state right-of-way. Approval of this resolution will authorize the Mayor to execute the agreement between the State of Texas and the City of Socorro, allowing the City to proceed with the replacement of its City Pride Signs and assume maintenance responsibilities as outlined in the Municipal Maintenance Agreement.

BACKGROUND

Previously City Council authorized the Mayor to execute a Municipal Maintenance Agreement with TxDOT. The need for the MMA was identified during the City's efforts to replace the existing City Pride Signs located at key entrances into the City. TxDOT requires municipalities to have an active MMA in place before applying for and participating in the City Pride Sign Program. With the MMA now approved, the next step in the process is for the City to enter into the City Pride Sign Agreement. This agreement grants permission for the construction or reconstruction of City Pride Signs within the state right-of-way in accordance with approved construction plans. The agreement also establishes the City's responsibility for the ongoing maintenance of the signs.

STATEMENT OF THE ISSUE

City Council must authorize the Mayor to execute the City Pride Sign Agreement with the State of Texas in order for staff to continue the process of replacing the City's entrance signs through the TxDOT City Pride Sign Program. Approval of the agreement is required before construction or reconstruction of the signs within the state right-of-way can proceed.

FINANCIAL IMPACT

None

ALTERNATIVE

Denial

STAFF RECOMMENDATION

Approve

Rudy Cruz Jr.
Mayor

Ruben Reyes
Representative
At Large

Cesar Nevarez
District 1



Alejandro Garcia
District 2

Gina Cordero
District 3/ Mayor Pro Tem

Irene Rojas
District 4

Adriana Rodarte
City Manager

RESOLUTION _____

A RESOLUTION AUTHORIZING MAYOR TO SIGN THE AGREEMENT BETWEEN THE STATE OF TEXAS AND THE CITY OF SOCORRO, TO PARTICIPATE IN THE TEXAS DEPARMENT OF TRANSPORTATION CITY PRIDE SIGN PROGARM.

NOW THEREFORE, BE IT RESOLVED BY THE CITY COUNCIL OF THE CITY OF SOCORRO:

That the City Pride Sign Agreement between the State of Texas and the City of Socorro, for the for participation in the Texas Department of Transportation City Pride Sign Program in the City of Socorro is hereby approved; and that Mayor is hereby authorized to execute said agreement on behalf of the City of Socorro and to transmit the same to the State of Texas for appropriate action.

READ, APPROVED AND ADOPTED this _____ day of _____ 2026.

CITY OF SOCORRO, TEXAS

Rudy Cruz, Mayor

ATTEST:

Olivia Navarro, City Clerk

APPROVED AS TO FORM:

James A. Martinez
Socorro City Attorney

STATE OF TEXAS §

COUNTY OF TRAVIS §

CITY PRIDE SIGN AGREEMENT

THIS AGREEMENT, made on the dates hereinafter shown, by and between the State of Texas, hereinafter called the "State," represented by the Executive Director of the Texas Department of Transportation, acting for and in behalf of the Texas Transportation Commission, and the City of Socorro, hereinafter called the "City."

WITNESSETH

WHEREAS, the State owns, operates, and maintains a system of highways for public use and benefit, in the City of Socorro; and

WHEREAS, the City desires and has requested authority to construct or have reconstructed the City Pride Sign along the roadway(s) of:

- North Loop Drive,
- Alameda Avenue,
- Socorro Road,
- Horizon Boulevard,
- Gateway Boulevard East, and
- Interstate Highway – 10 West

at the location(s) shown on construction plans, attached hereto and made part of this Agreement.

NOW, THEREFORE, in consideration of the premises and of the mutual covenants and agreements of the parties hereto, to be by them respectively kept and performed as hereinafter set forth, and in accordance with Title 43, Texas Administrative Code, Chapter 25, Subchapter H, it is agreed as follows:

A G R E E M E N T

Article 1. General

The State grants to the City permission to construct or to have reconstructed, the City Pride Sign(s) within the right-of-way as shown on construction plans and to be maintained by the City as stipulated in the Municipal Maintenance Agreement with the City of Socorro, dated November 20, 2025.

Article 2. Plans, Specifications and Construction Procedures

A. The City, at no cost to the State, shall prepare or have prepared, complete construction drawings, plans and specifications for the proposed City Pride Sign(s), State approved breakaway sign supports, foundations, appurtenances, and incidental items. No construction work shall be performed on highway right-of-way until these plans and specifications have been approved in writing by the State. After such approval has been given, no changes or alterations shall be made without the written approval of the State.

B. The plans and specifications shall be submitted to the District Engineer, Texas Department of Transportation, (TxDOT District), Texas for approval. Any changes or alterations which become necessary during the course of the work shall also be submitted to the District Engineer for approval.

C. The City, its contractor(s), or agents shall submit a traffic control plan as required and in accordance with the Texas Manual on Uniform Traffic Control Devices to direct and protect vehicular and pedestrian traffic while construction work, including related activities, is in progress. Details and descriptions of these traffic handling measures shall be included in the plans and specifications when submitted for approval. If, during construction, it becomes necessary or desirable to modify the traffic control measures as specified, prior approval must be obtained from the State's District Engineer in (TxDOT District).

D. The City shall construct, or have constructed, at its entire cost and expense, the proposed City Pride Sign(s) and incidental items referred to in paragraph 1 and 2 above. The State shall have the right to inspect the work on highway right-of-way at any time during the progress of the work, and to make final inspection upon completion. Construction operations will be conducted in a manner acceptable to the District Engineer or their authorized representative. The City, its contractor(s) or agents shall correct any deficiencies revealed by the State's inspection of the work or of the traffic control and protection measures, where such deficiencies could have an adverse affect on public use of the highway or the safety and convenience of the traveling public.

E. Upon completion of the work authorized herein, the City shall submit copies of the as-built plans and specifications, including any changes or alterations, showing the City Pride Sign(s) in their completed state within 45 days to the State's District Engineer in (TxDOT District) for permanent records of the State.

F. The City agrees to pay all damages accruing to the State, by reason of injuries to the right-of-way, roadbed, pavement, and/or bridge owned by the State, when such damages are caused by the city's construction, operations, maintenance or rehabilitation on said roadway. Whenever funds are paid by the City to the State under this Agreement, the City shall remit a check or warrant made payable to the "Texas Department of Transportation Trust Fund." To the extent allowed by law, the City also agrees to indemnify and save harmless the State from any and all claims, demands, actions or causes of action, due to damage to property or injury to or death of persons arising from or growing out of or in any manner connected with work on said roadway project including, but not limited to, all court costs, attorney fees and other expenses incurred in connection with suits for such damage and shall, if so requested in writing, assist or relieve the State from defending any such suits brought against it. In addition, the City shall require its contractor(s) and subcontractor(s) to secure a policy of insurance in the maximum statutory limits for tort liability, naming the State as an additional insured under its terms, and maintain the required insurance coverages in full force and effect during any period that work is performed on the State right-of-way. Adequate insurance, as a minimum, shall mean the City contractor(s) shall furnish the State with the Texas Department of Transportation's Certificate of Insurance covering the below listed insurance coverages.

- 1) Worker's Compensation Insurance Amount – Statutory
- 2) Comprehensive General Liability Insurance

Amounts	Bodily Injury	\$600,000 combined single limit each
	Property Damage	occurrence and in the aggregate

OR

- Commercial General Liability Insurance

Amounts	Bodily Injury	\$250,000 each person
	Property Damage	\$100,000 each occurrence

- 3) Texas Business Automobile Policy

Amounts	Bodily Injury	\$250,000 each person
	Property Damage	\$100,000 each occurrence

The State shall be included as an “Additional Insured” by Endorsement to policies issued for coverages listed in B and C above. A “Waiver of Subrogation Endorsement” in favor of the State shall be a part of each policy for coverages listed in A, B, and C above. A certified copy of these endorsements shall be submitted to the State with the evidence of coverage. The City and/or its contractor(s) shall be responsible for any deductions stated in the policy.

Article 3. Location

A. One City Pride and/or a Texas Commission on Environmental Quality (TCEQ), Texas Historical Commission (THC), Keep Texas Beautiful (KTB) Sign shall be allowed per eligible highway entrance to the City. A City Pride Sign shall be located on the right-hand side of the roadway unless otherwise approved in writing by the State. A City Pride Sign shall be located between 300 and 800 feet of the city limits at a location approved by the State. A City Pride Sign shall take advantage of the natural terrain, have the least impact on the scenic environment, avoid visual conflict within the State highway right-of-way, have a lateral offset greater than existing guide signs, not block the motorist’s view of existing traffic control signs, and be placed in locations other than hanging above the highway.

B. A City Pride Sign shall not be located adjacent to the main lanes of full controlled access highway; however, a City Pride Sign may be located on the right-hand side of the access road.

C. The city may landscape the area adjacent to the City Pride Sign(s) upon written approval of the plans by the State’s District Engineer in the (TxDOT District) District. Only small plants, flowers, and shrubbery will be allowed. Permanent structures or items such as large stones, masonry, berms, landscape timbers, etc. shall not be allowed. The State assumes no responsibility for watering, maintenance or damage due to State maintenance and construction activities, fire, theft or vandalism.

Article 4. City Pride Sign

A. The sign face of a City Pride Sign or the combined total area of the attachment signs displayed shall not exceed 80 square feet total. A City Pride Sign shall not contain words, symbols, or messages that:

- 1) May be construed as advertising, including, but not limited to, the offering of products and services.
- 2) Contain notification of municipal ordinances or regulations, or
- 3) Resemble official traffic control devices.

B. Banners, flags, streamers, flashing lights, or other appurtenances shall not be attached to a City Pride Sign or sign supports. Sign supports shall be galvanized metal or painted solid white.

C. A City Pride Sign shall not be illuminated internally or externally.

D. A City pride Sign may contain the name of the city, message, or slogan no greater than eight inches in height. The City may include a seal or symbol that is commonly used to represent the City.

E. If a City Pride Sign requires background material, it shall be painted brown (Sherwin Williams #2315 or equivalent) or have brown reflective material affixed to the sign face meeting State specifications. Lettering upon the brown background shall be white and

may be any script or font. A white 2 inch border is optional. Lettering and border shall be painted white (Sherwin Williams #2130 or equivalent) or have white reflective material affixed to the sign face meeting State specifications.

Article 5. Attachment Signs

A. Attachment signs or civic information signs are provided by a non-profit civic organization or governmental entity that display points of interest or geographical, recreational, cultural, or civic information. A civic organization must be located within or have a member who resides in the City, and complies with all applicable law concerning the provisions of public accommodation without regard to race, religion, color, sex, or national origin.

B. Attachment signs may be any color or combination of colors and may be in any design or shape. Attachment signs shall not be greater than 48 inches in width and 36 inches in height, and shall not consist of text, symbols, trademarks or a legend message identifying the name or abbreviation of a commercial establishment, service or product, or contain supplemental address or directional information such as meeting dates or locations.

C. A civic organization shall apply to the City for permission to display an attachment sign upon the City Pride Sign. The City shall notify/contact the civic organization in writing if the civic organization does not meet the requirements of eligibility as stated herein. The civic organization shall have 30 calendar days after written notification to meet the requirements herein.

D. The City shall approve all attachment signs and determine the order, arrangement, and duration of display. Attachment signs shall be placed upon a City Pride Sign and shall not overlap.

E. A civic organization shall have only one attachment sign per City Pride Sign unless the City and civic organization agree to said organization’s multiple attachment signs upon a City Pride Sign.

F. The City shall remove an attachment sign of a participating civic organization if the civic organization ceases to exist, does not meet the requirements stated herein, or has not provided a replacement sign after 60 days of the City or State’s written notification that the attachment sign is damaged, broken, faded, or has become a hazard due to failure to build to specifications, inclement weather, inadequate maintenance, accidental damage, or other cause.

Article 6. Miscellaneous

A. Signs from the TCEQ, THC, or KTB, Proud Community Program signs, shall be erected and maintained to State specifications at the sole expense of the City. Signs shall not be allowed as attachments to State signs or sign supports.

B. Attachment signs not relocated to a City Pride Sign, TCEQ, THC, or KTB signs or other approved locations will be removed by the State at the expense of the City.

C. The State shall not require fees from the City for participating in the City Pride Sign Program. The city shall not require fees from the civic organizations or governmental entities for display upon a City Pride Sign.

D. While installing or maintaining a City Pride Sign, the City shall cooperate with any State contractor working on the State highway system at that location.

E. In the event that the State determines that it is necessary to repair, construct, reconstruct and/or make any changes in the highway facility for reasons other than those specified herein, the City shall be responsible for all costs necessary for removal and relocation of the City Pride Sign.

F. The City shall remove a City Pride Sign if it has not provided a replacement sign within 60 calendar days of written notification from the State that the sign is damaged, broken, faded or has become a hazard due to failure to build to specifications, inclement weather, inadequate maintenance, accidental or other cause. After 60 days, the City Pride Sign not removed or replaced will be removed by the State at the expense of the city. The State may terminate this agreement upon default of the city.

G. This Agreement shall bind, and shall be for the sole and exclusive benefit of the respective parties and their legal successors.

IN TESTIMONY WHEREOF, the parties hereto have affixed their signatures, the City of Socorro on the 2 day of July, 2026, and the State on the ____ day of _____, 2026.

THE CITY OF SOCORRO
Executed on behalf of the City by:

By _____ Date _____

Typed or Printed Name and Title _____

ATTEST:

By _____ Date _____

Typed or Printed Name and Title _____

THE STATE OF TEXAS

Executed for the Executive Director and approved for the Texas Transportation Commission for the purpose and effect of activating and/or carrying out the orders, established policies or work programs heretofore approved and authorized by the Texas Transportation Commission.

By _____ Date _____
_____ District Engineer

Option C
Two Post/Solid Background
Max. 80 sq. ft.

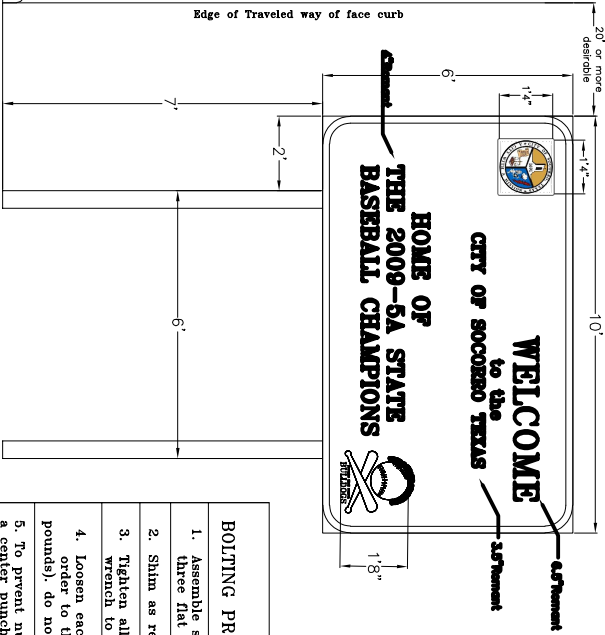

- LATERAL CLEARANCE NOTES:**
10. Lateral Clearances of signs mounted on median side of main lanes are the same as shown. Where space will permit.
 11. Where a sign is to be located behind guardrail, an allowable minimum clearance of five feet may be used, measured from the face of the guardrail to the rear edge of sign.
 12. 5' minimum and desirable may be used only in areas of limited lateral clearance and when approved by the Engineer.
- POST SPACING NOTES:**
13. Post Spacing on a two post sign may vary a maximum of plus or minus 10% of total sign width to fit field conditions.
 14. Typical maximum dimensions are 10 foot width by 8 foot height, however TxDOT will consider other shapes and designs upon request. Maximum size of sign face shall not exceed 80 square feet.
 15. Background shall be brown in color.
 16. Optional City name, symbols, slogan or combination thereof may be used on the sign face. Lettering may be any size or font, but shall not be greater than 8 inches in height. Lettering and or optional 2 inch border shall be white in color.

- BOLTING PROCEDURE FOR ASSEMBLY OF BASE CONNECTION**
1. Assemble sign post, bolt keeper plate, and stub post with bolts and three flat washers per bolt, as shown.
 2. Shim as required, to plumb post.
 3. Tighten all bolts to the maximum possible with a 12 to 15 inch wrench to clean bolt threads and to bed washers and shims.
 4. Loosen each bolt in sequence and retighten bolts in a systematic order to the prescribed torque (440-450 inch pounds, 36-38 foot pounds), do not overtighten.
 5. To prevent nut loosening, burr threads of bolt at junction with nut using a center punch.

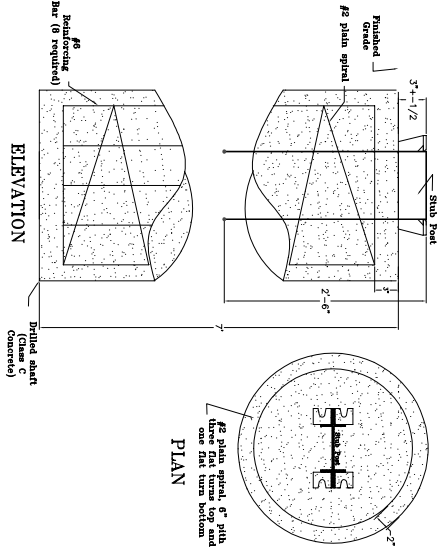

FOUNDATION DETAIL

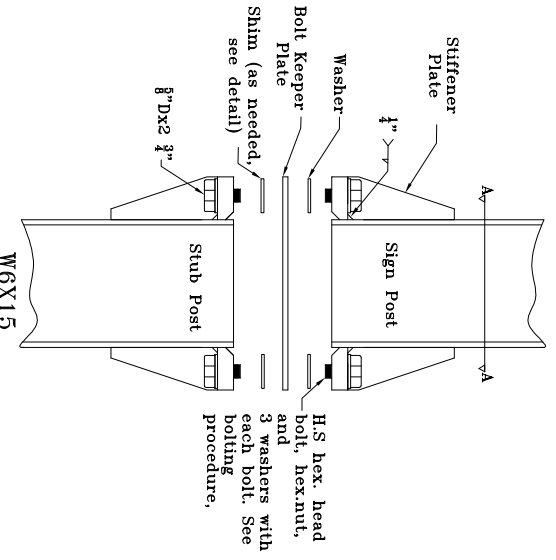

SIGN POST AND STUB POST

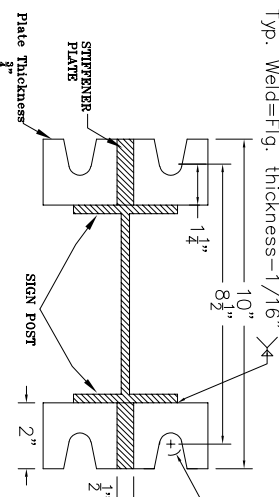

SECTION A-A

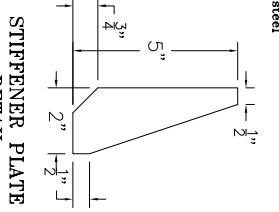

STIFFENER PLATE DETAIL

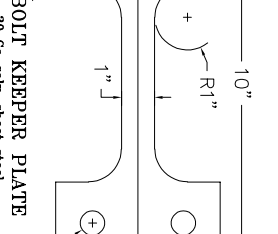

BOLT KEEPER PLATE

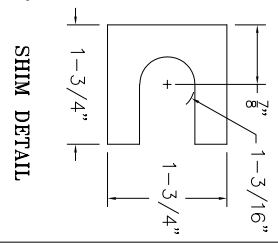

SHIM DETAIL

SHIM DETAIL.
Shim shall be fabricated from brass shim stock or strip conforming to ASTM B36. Shims shall have a thickness of .012" or .032"

Steel plate (thickness = 1/2")

CITY PRIDE SIGN
OPTION C

General Notes	
<p>PK&Z Department 860 Rio Vista Socorro, Texas 79927</p>	<p>City Pride Sign Option C 6'x10'</p>
<p>Revised By Date</p>	<p>Revised/Issue Date</p>
<p>Drawn By Date</p>	<p>Checked By Date</p>
<p>1/16/2009</p>	<p>NTS</p>

CITY PRIDE SIGN PROGRAM

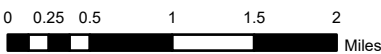
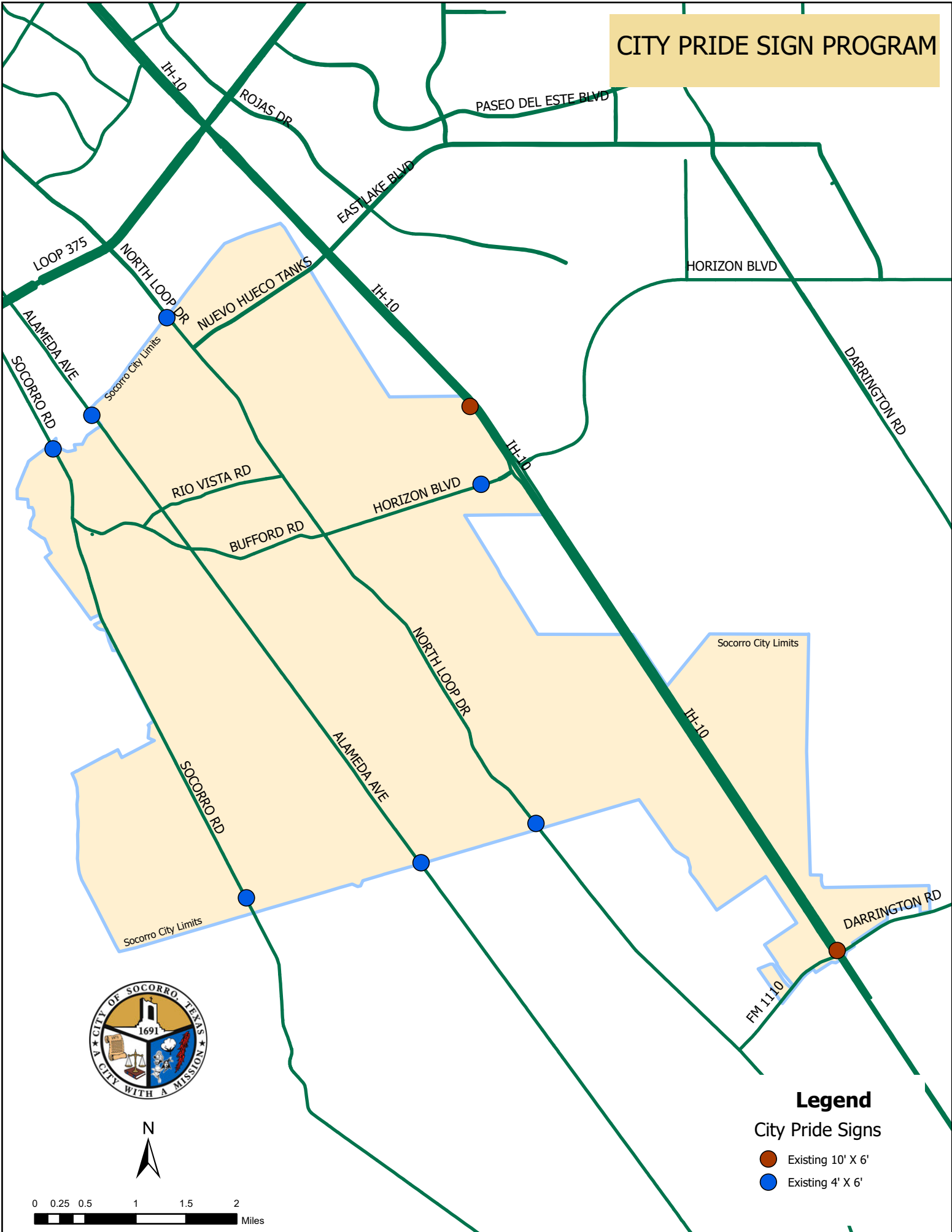

- Legend**
- City Pride Signs
- Existing 10' X 6'
 - Existing 4' X 6'

ITEM 15

Rudy Cruz Jr.
Mayor

Ruben Reyes
At Large

Cesar Nevarez
District 1



Alejandro Garcia
District 2

Gina Cordero
District 3/ Mayor Pro-Tem

Irene Rojas
District 4

Adriana Rodarte
City Manager

TO: MAYOR AND CITY COUNCIL MEMBERS

FROM: Mayor, Rudy Cruz Jr.

SUBJECT: *Discussion and Action* to Direct Staff to Research and Prepare Recommendations Regarding the Regulation of Shipping Container Homes and Commercial use within the City.

SUMMARY

Interest in alternative and affordable housing options has increased in recent years, including the use of repurposed shipping containers as residential structures. Shipping container homes have been adopted in various jurisdictions throughout Texas and the United States as a potential housing option

At present, the City's Code of Ordinances may not specifically address shipping container homes. As a result, clarification may be needed regarding whether such structures should be permitted, restricted, or prohibited within certain zoning districts and under what conditions.

Purpose:

The purpose of this agenda item is to allow the Mayor and City Council to provide direction to staff regarding the evaluation of shipping container homes and the development of potential ordinance amendments.

Recommended Council Action:

Direct City staff to:

1. Research state and local regulations applicable to shipping container homes and commercial uses.
2. Review ordinances and best practices from other Texas municipalities and comparable jurisdictions.
3. Evaluate building code, zoning, public safety, infrastructure, and aesthetic considerations associated with shipping container homes and commercial uses.
4. Identify potential benefits, including affordable housing opportunities, sustainability, and redevelopment options.

5. Identify potential concerns, including compatibility with existing neighborhoods, structural requirements, appearance standards, and enforcement considerations.
6. Prepare and present to the Mayor and City Council a report with findings and recommendations, including options to:
 - o Permit shipping container homes subject to standards and conditions;
 - o Restrict shipping container homes to specific zoning districts;
 - o Establish design, appearance, and construction requirements;
 - o Prohibit shipping container homes if deemed incompatible with community objectives.

STATEMENT OF THE ISSUE

Same as above

FINANCIAL IMPACT

Account Code (GF/GL/Dept):

Funding Source: N/A

Amount: N/A

Quotes (Name/Commodity/Price) N/A

Co-op Agreement (Name/Contract#) N/A

ALTERNATIVE

Deny Request

STAFF RECOMMENDATION

Approve Request

REQUIRED AUTHORIZATION

1. City Manager _____ Date _____
2. CFO _____ Date _____
3. Attorney _____ Date _____