

City of Socorro Projects Update



DANNENBAUM
ENGINEERING CORPORATION

Rev. January 2021

Overview

1. General Engineering
2. Major Thoroughfare Plan
3. Master Sidewalk Plan
4. Update for On Going Projects

Major Thoroughfare Plan

- **City Manager made decision to invest in Major Thoroughfare for City of Socorro in August 2016**
- **Thoroughfare Plan Included following:**
 - Traffic Capacity Analysis
 - Safe Route to School
 - Master Sidewalk Plan
 - Roundabout Study
 - Transit Plan
- **Thoroughfare Plan was Completed in November 2018**
- **With the Completion of Thoroughfare Plan City, City began looking for Funding for Projects identified in the Plan.**

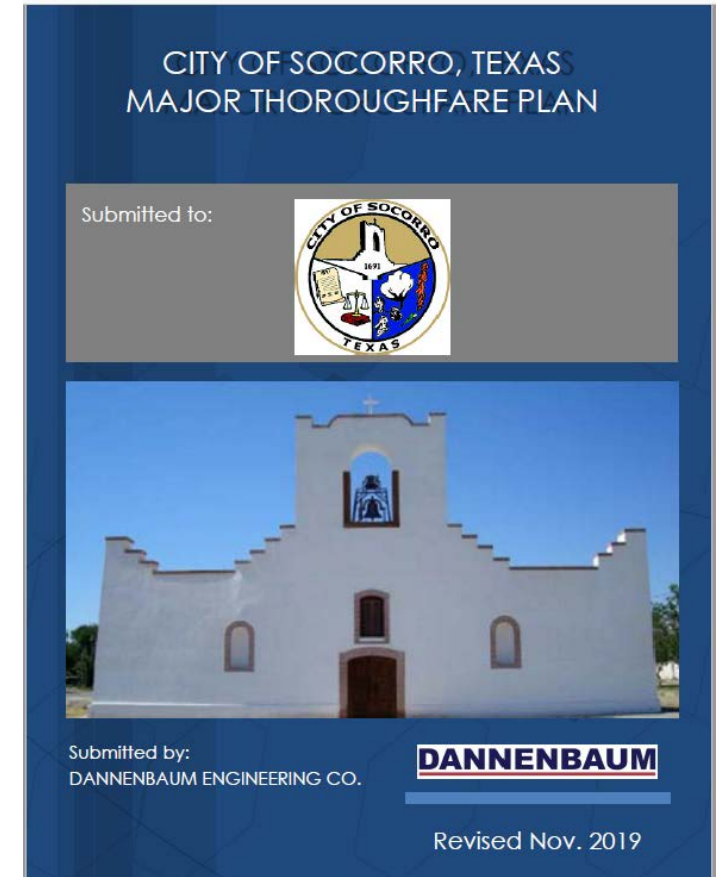

Major Thoroughfare Plan

CITY OF SOCORRO: IMPROVEMENT PLAN

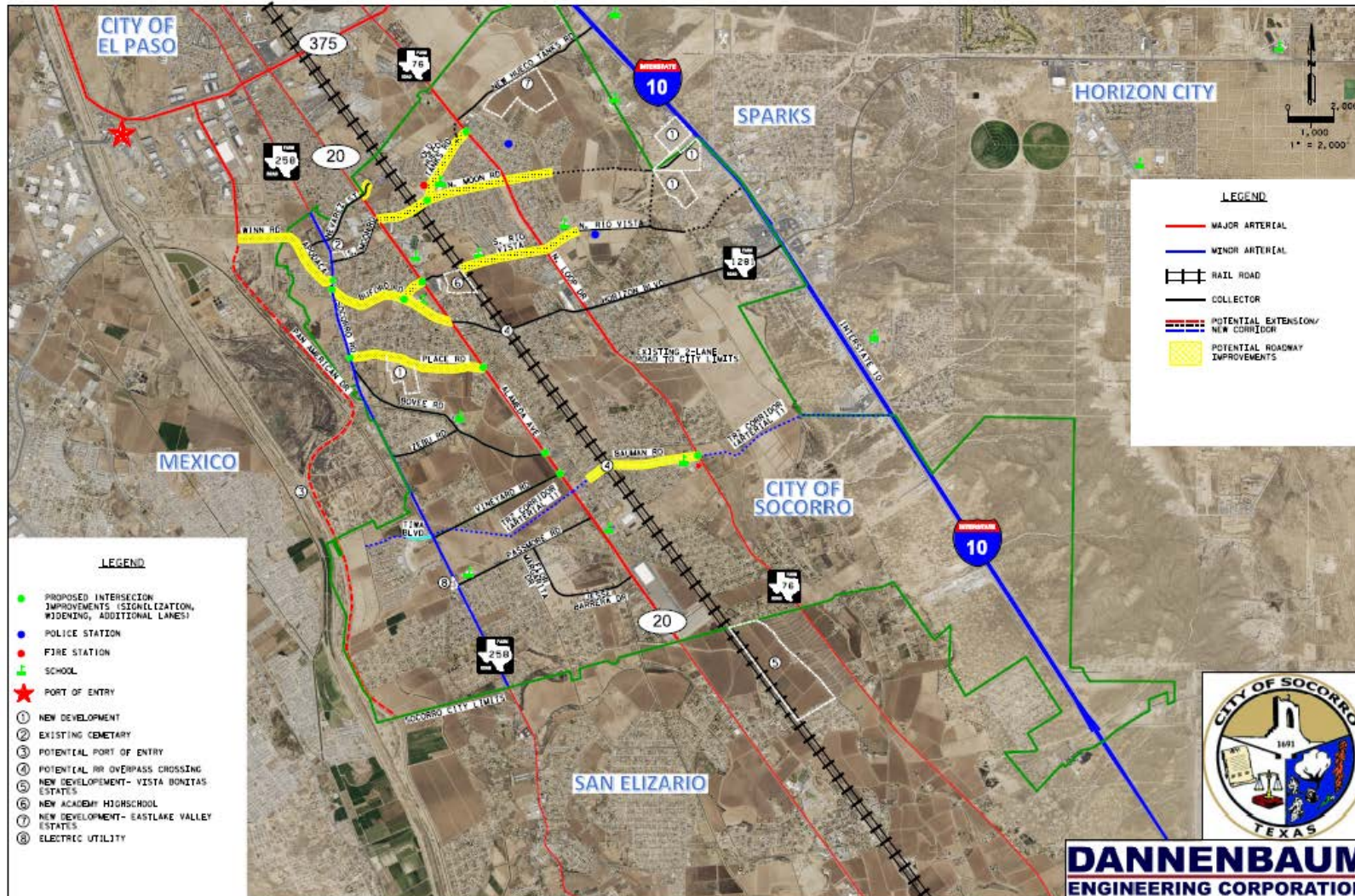

Plan Identified Several Needed Roadway Improvement Projects

- 7 High Priority Projects
- 5 Mid Priority Projects
- 10 Intersection Projects

Master Sidewalk Plan

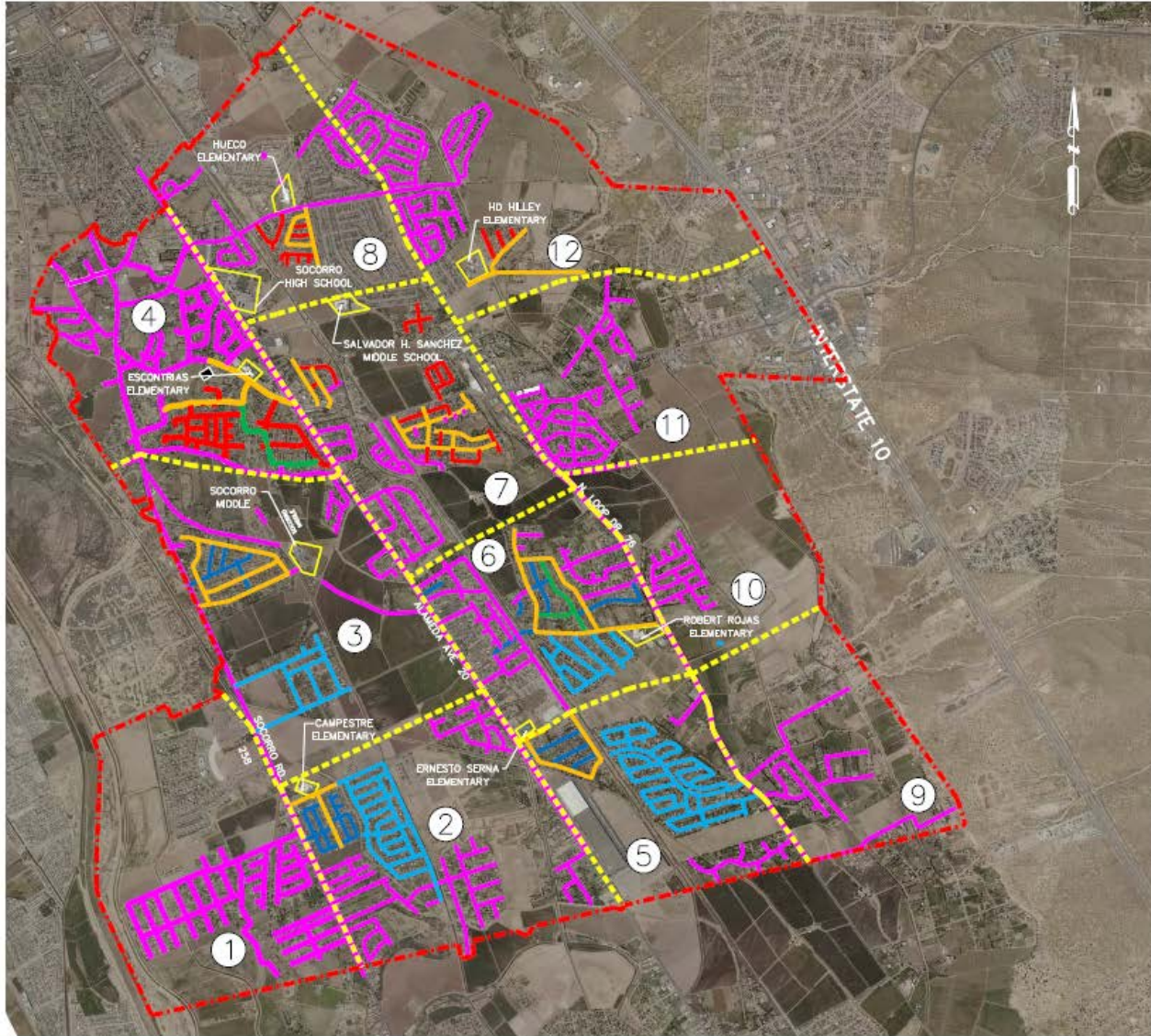

- LEGEND**
- SRTS PHASE I (COMPLETED)
 - SRTS PHASE II (COMPLETED)
 - SRTS PHASE III-A
 - SRTS PHASE III-B
 - SRTS PHASE IV
 - SIDEWALK MASTER PLAN
 - SOCORRO CITY LIMITS
 - SIDEWALK MASTER PLAN

- Divided City into 12 Sections
- Identified the needs for sidewalks in each Sections
- Phase 1 has got to Bid



DANNENBAUM
 ENGINEERING CORPORATION - EL PASO, LLC
 T.S.P.E. FIRM REGISTRATION #14531
 10142 GARDNER ROAD, SUITE 110, EL PASO, TX 79905 (915)824-2400

CITY OF SOCORRO
 MASTER SIDE WALK PLAN

CITY OF SOCORRO
 TRANSITIONAL
 PLAN LAYOUT

PROJECT NO.	18-02	SHEET	SIXXII
STATE	TEXAS	CITY	SOCORRO
			ROADWAY

DANNENBAUM
 ENGINEERING CORPORATION

Sparks Arroyo Project

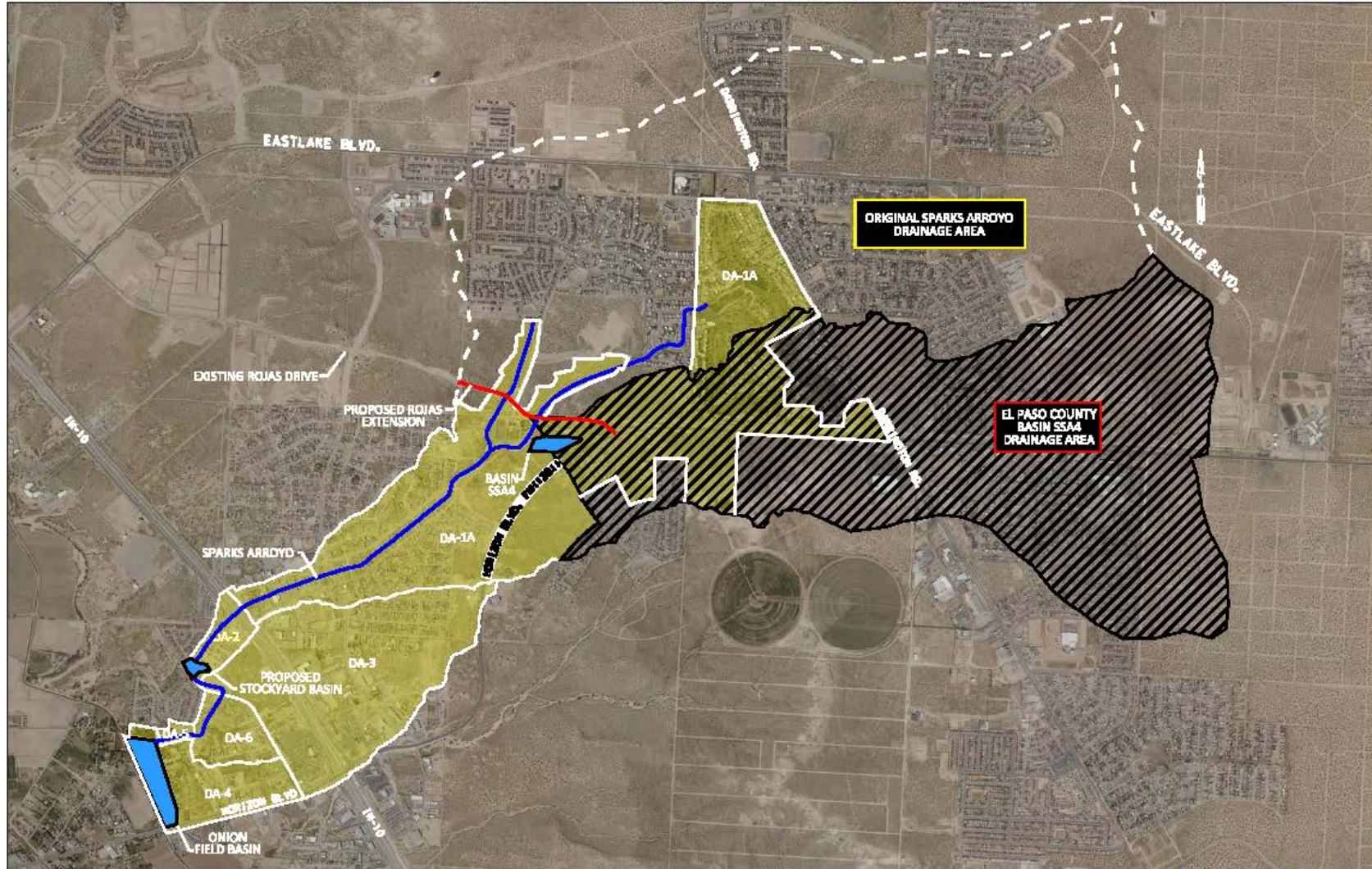

SPARKS ARROYO DRAINAGE AREA MAP WITH BASIN SSA4

DANNENBAUM

Sparks Arroyo Study
Completed: **November 2017**

DANNENBAUM
ENGINEERING CORPORATION

Sparks Arroyo Project



- Onion Field Basin Phase 1 Completed: May 2020
- Design for Onion Field Basin Ph. 2, Stockyard Detention Basin and Sparks Arroyo 95% Complete
- City Coordinating Partnership with El Paso County to share the cost for Construction

Rio Vista Bridge Replacement – Location Map





Existing Conditions – Rio Vista Rd. Bridge



Existing Rio Vista Rd. Bridge

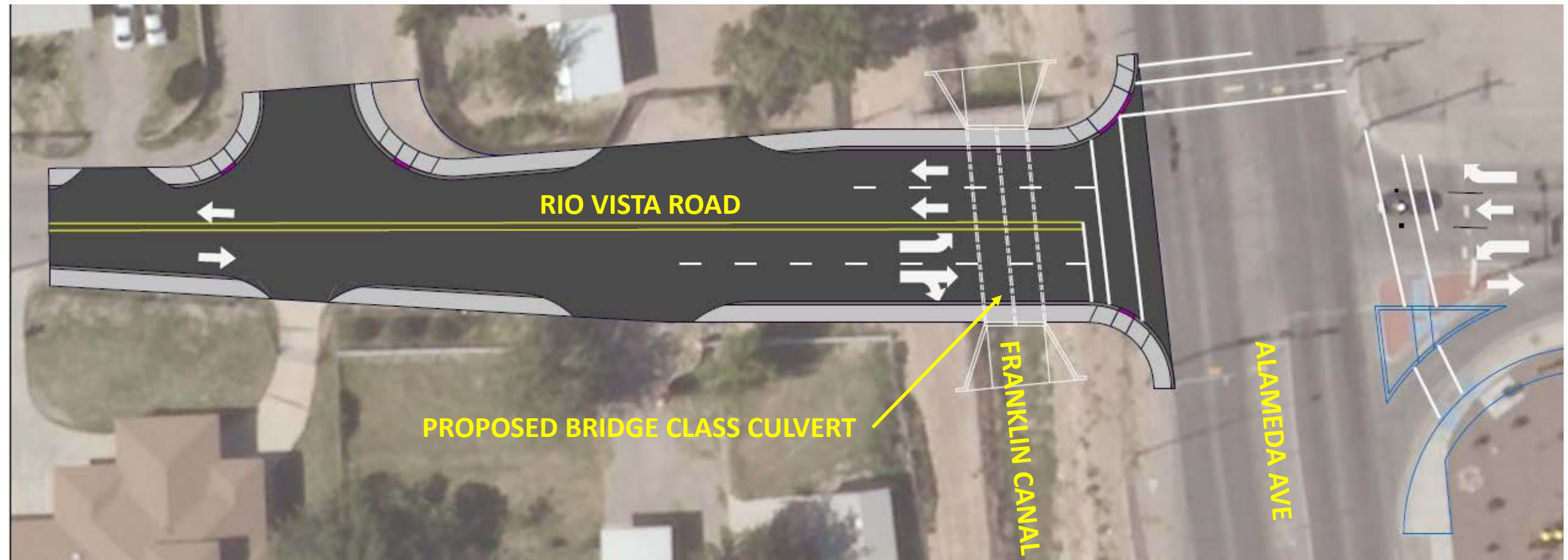

Proposed Layout Rio Vista Rd. Bridge

Rio Vista Bridge Replacement Project

Funding Approved : **August 2018**

State Funding Construction: **\$992,157**

Local Contribution: **\$ 56,818**

Project Preliminary Design Start Date: **September 2020**

Rio Vista Bridge Replacement Project - Timeline

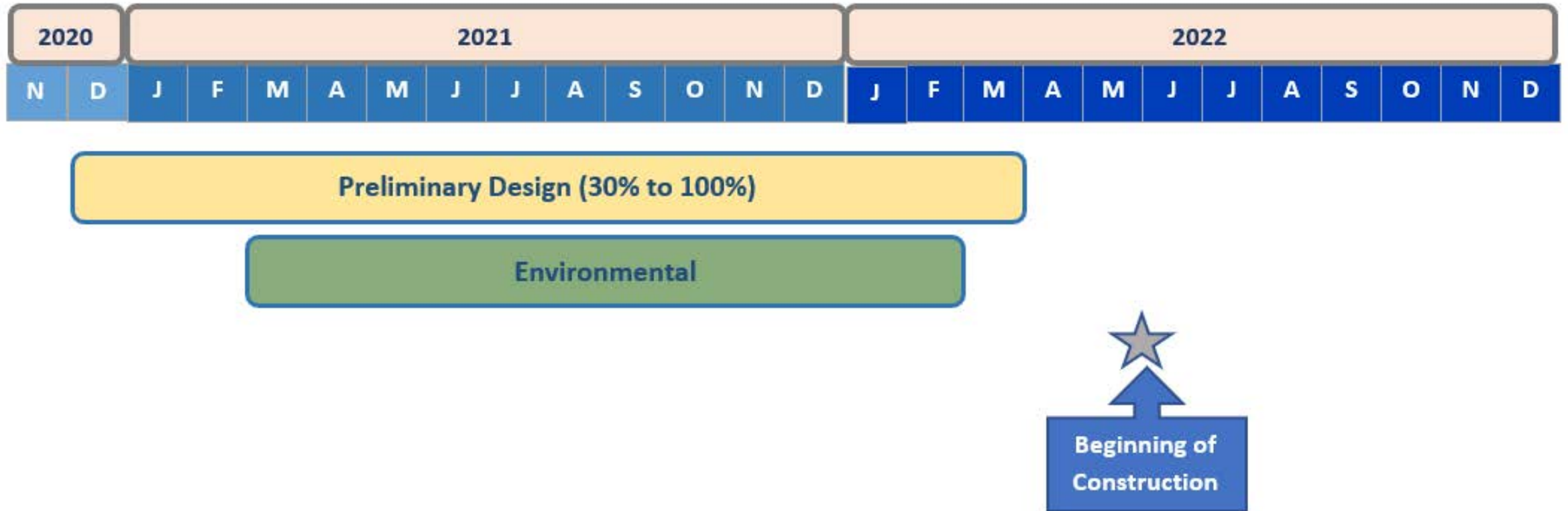

PROJECT LOCATION MAP

Bovee Rd. Bridge Project





Existing Conditions of the **Bovee Rd. Bridge**



Existing – Bovee Rd. Bridge

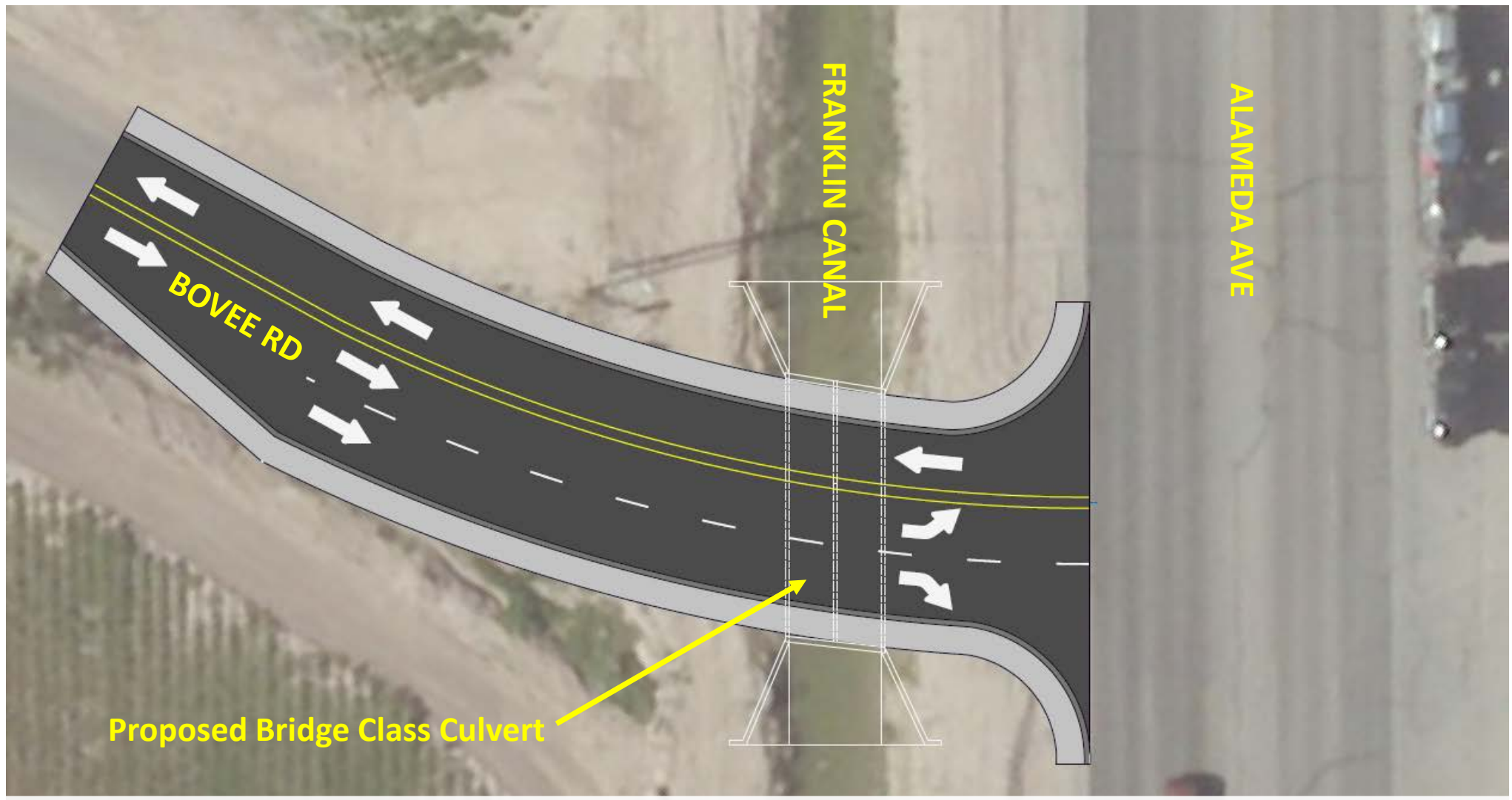

Proposed Layout – Bovee Rd. Bridge

Bovee Bridge Replacement Project

Funding Approved: **July 2020**

State Funding:

Construction: **\$965,521**

Local contribution: **\$ 55,179**

Project Preliminary Design Start Date: **August 2020**

Bovee Bridge Replacement Project - Timeline

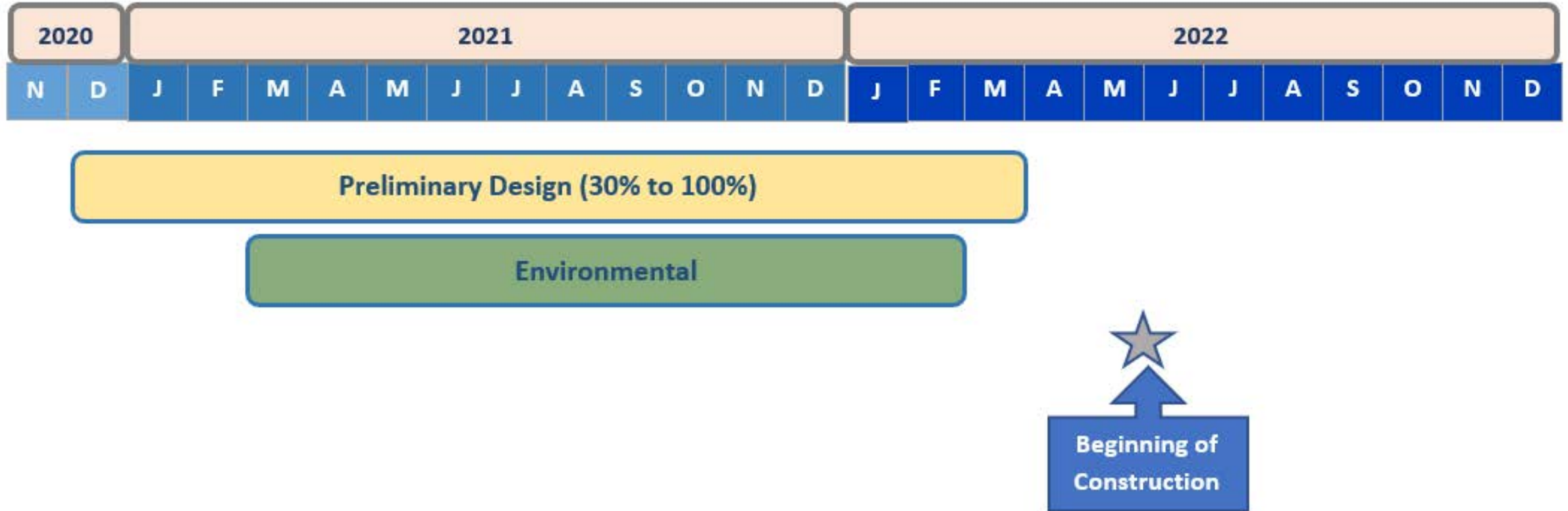

Passmore Shared-Use Path Project

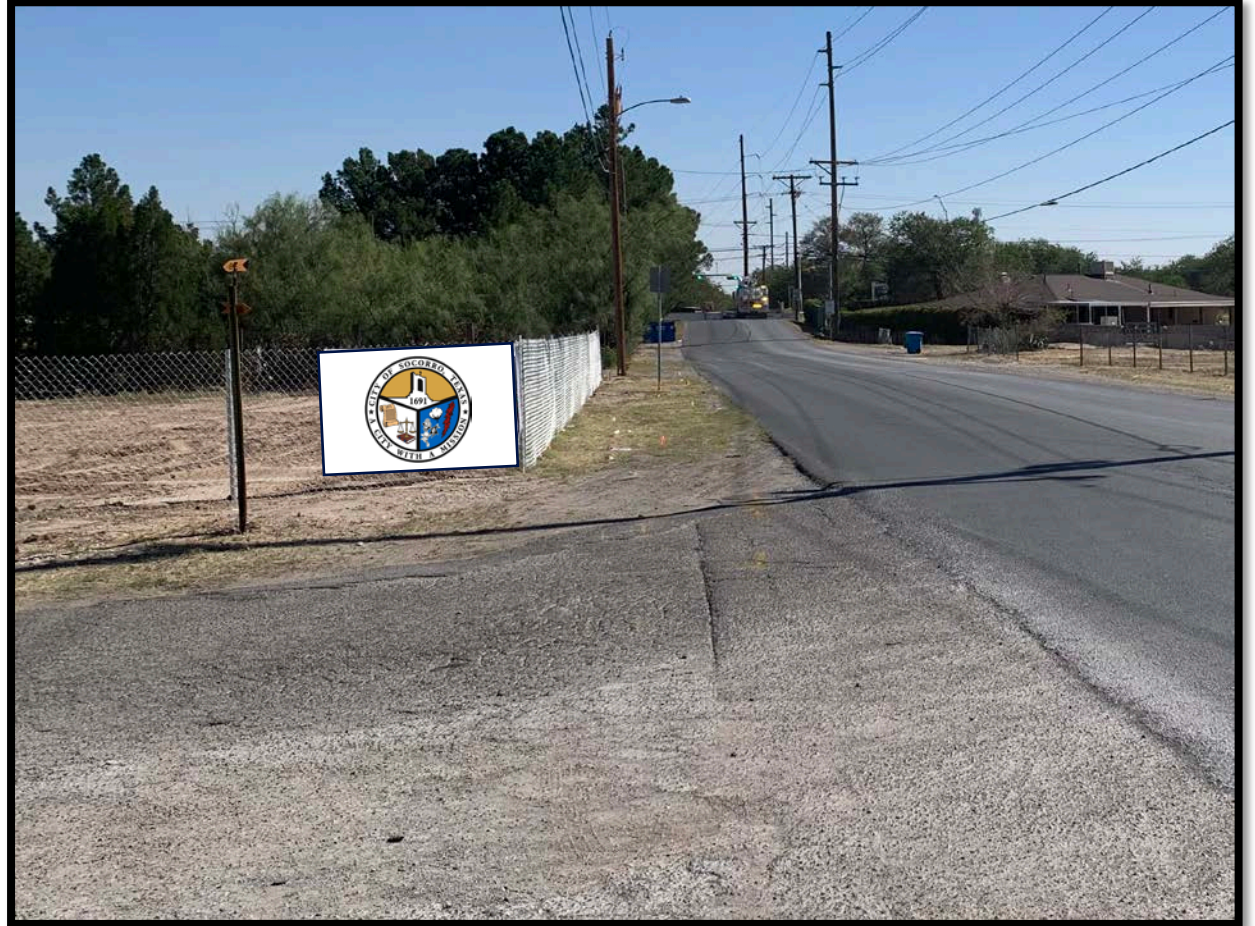
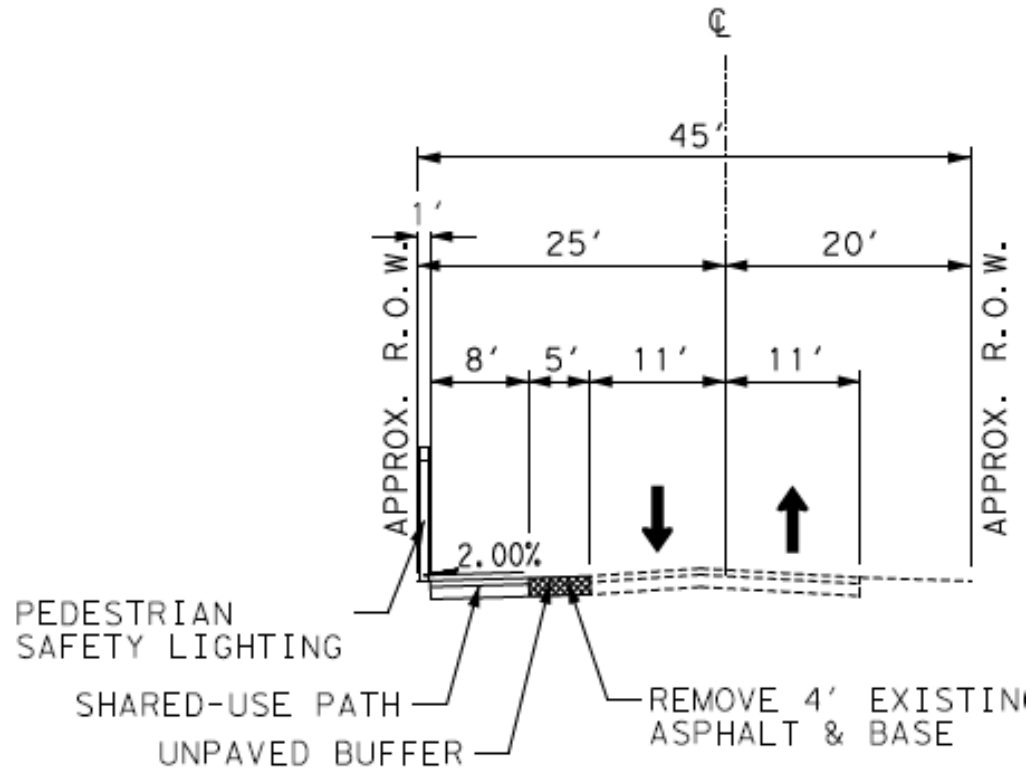

Passmore Shared-Use Path Project

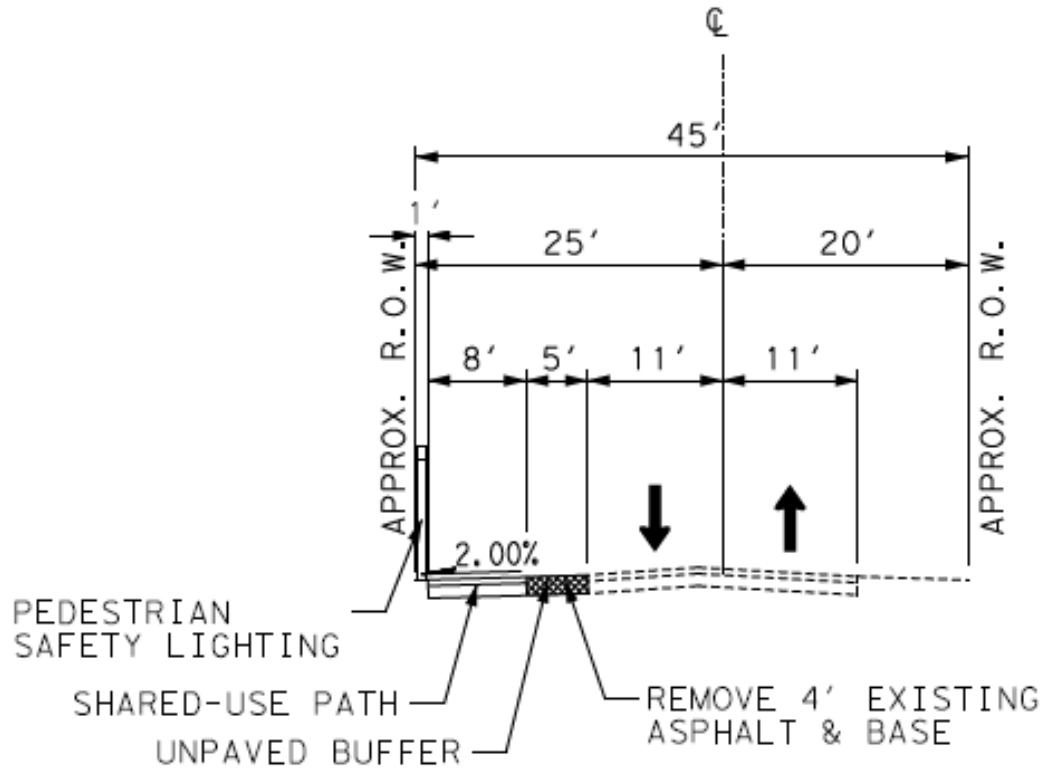

Passmore Shared-Use Path Project

Funding Approved by MPO: **January 2020**

Construction Funding: **\$ 786,537**

Local Contribution: **\$ 150,357**

Project Preliminary Design Start Date: **September 2020**

Passmore Shared-Use Path Project - Timeline

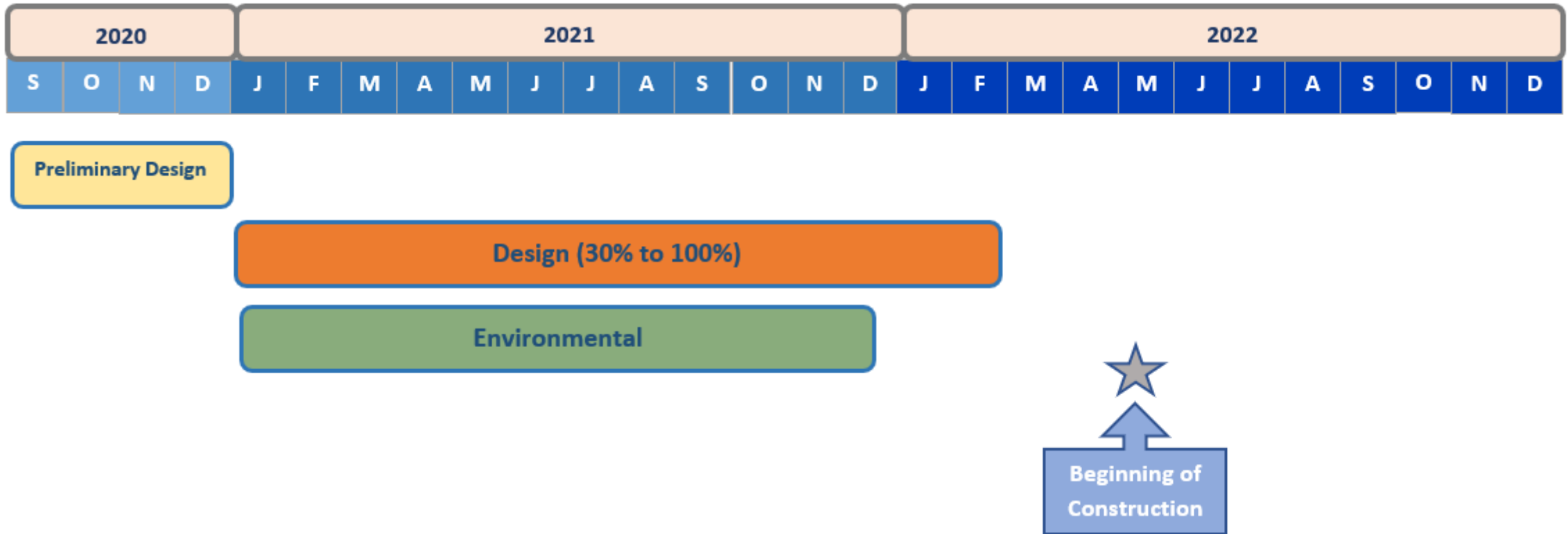

Arterial 1 / Tiwa Blvd.

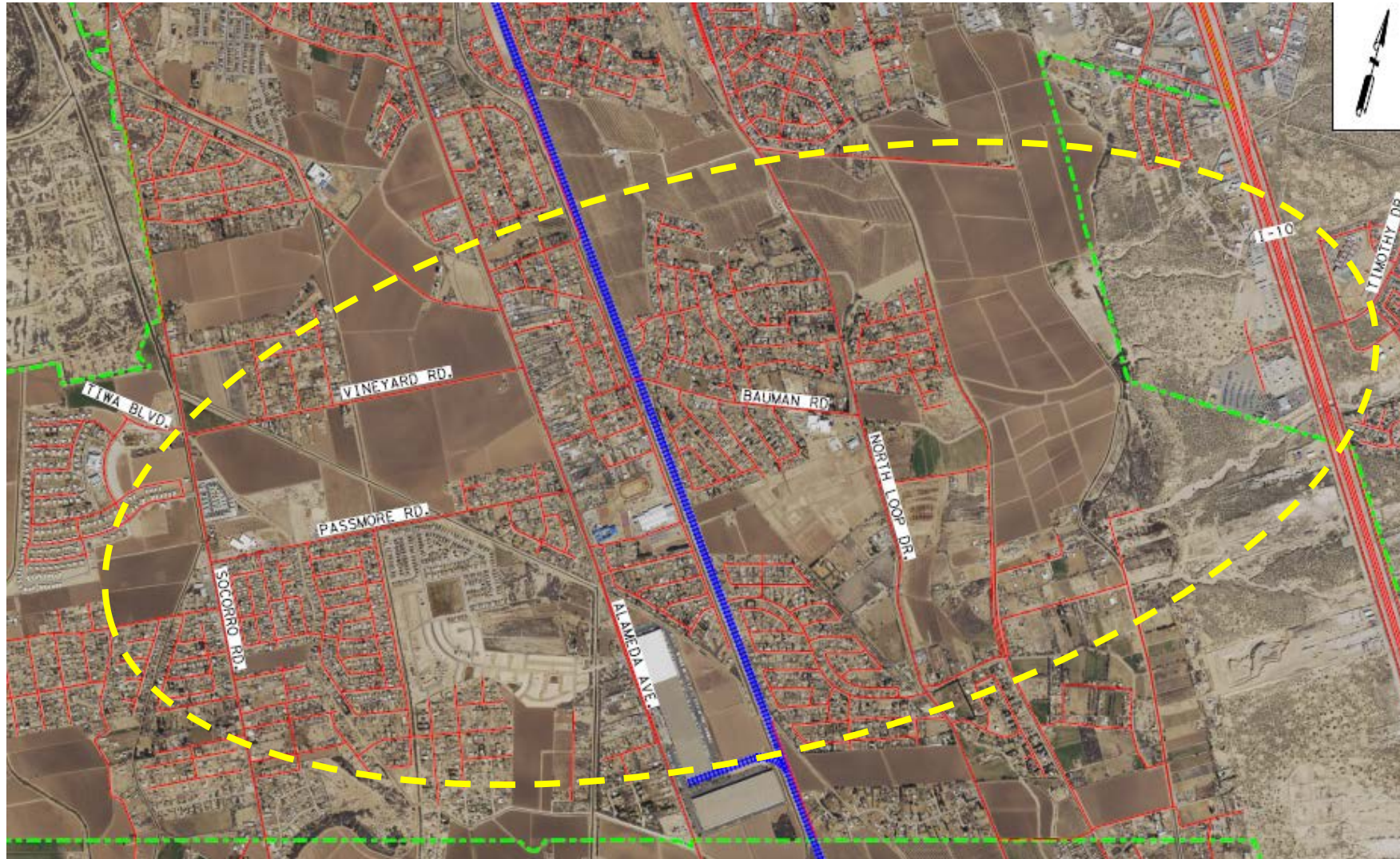

Arterial 1 / Tiwa Blvd.

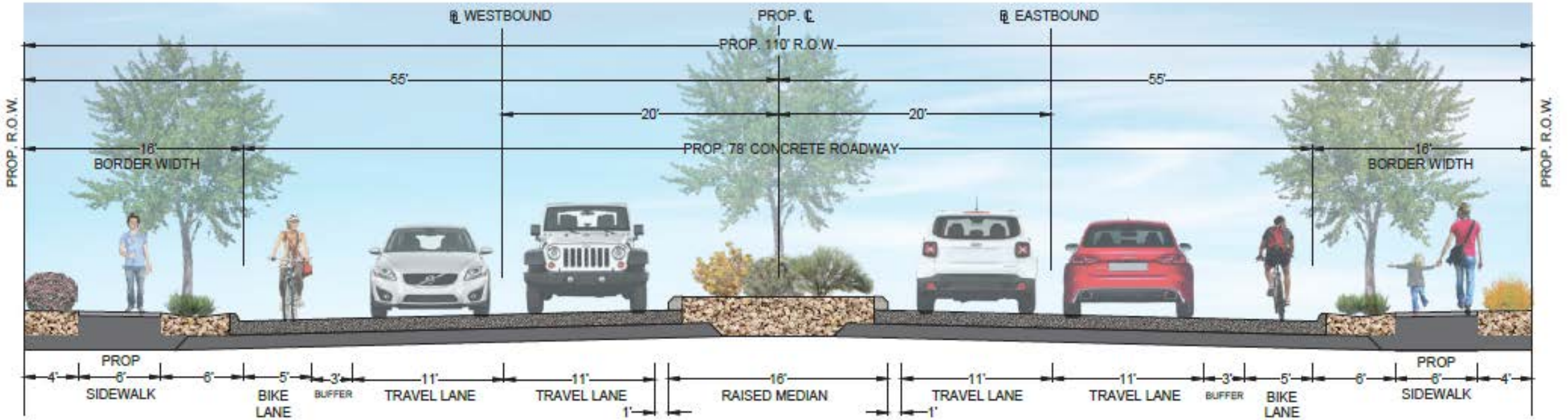

Arterial 1 / Tiwa Blvd.

Funding for Preliminary Engineering Approved by MPO: **Dec 2018**

Construction Estimate: **\$33.9M**

Project Preliminary Design Start Date: **August 7, 2020**

Arterial 1 / Tiwa Blvd. Project - Timeline

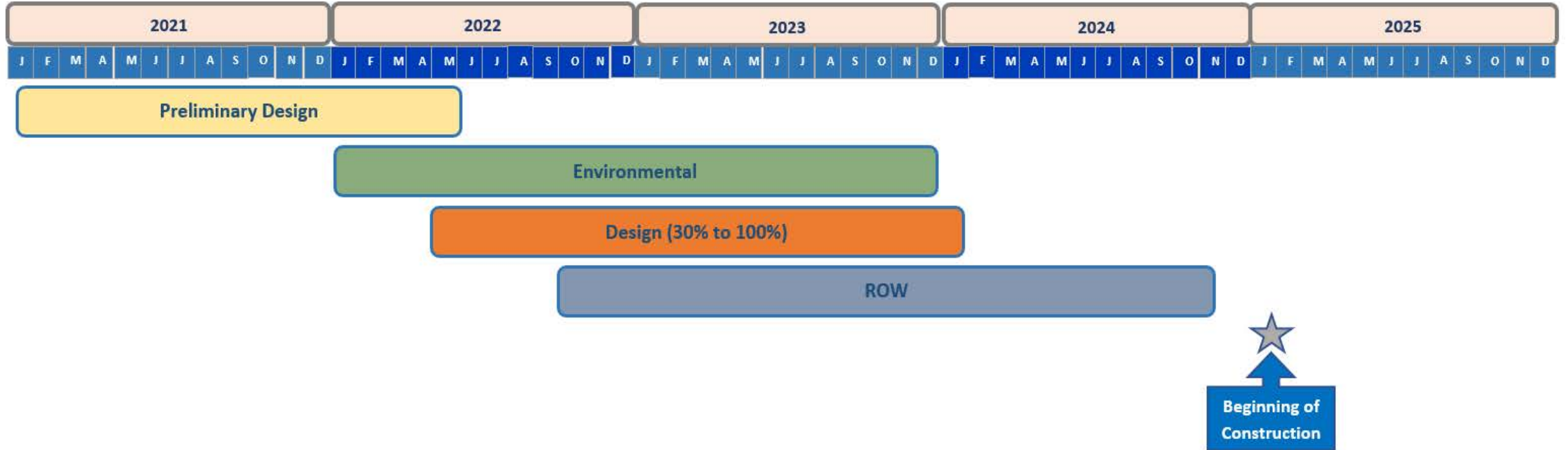

Nuevo Hueco Tanks Extension Project



Nuevo Hueco Tanks Extension Project

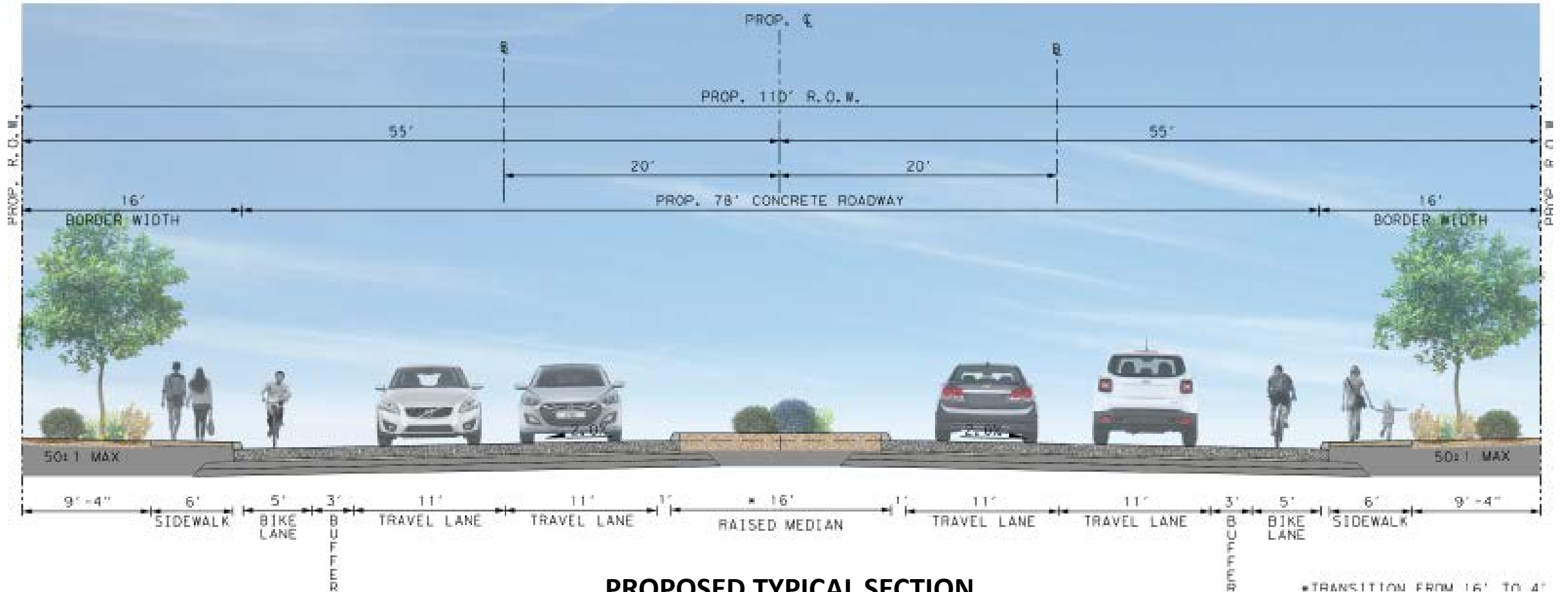

PROPOSED TYPICAL SECTION

DANNENBAUM
ENGINEERING CORPORATION

Nuevo Hueco Tanks Extension Project

Funding for Preliminary Engineering Approved by MPO: **July 2020**

Construction Funding: **\$20M**

Project Preliminary Design Start Date: **September 2020**

Nuevo Hueco Tanks Extension Project - Timeline

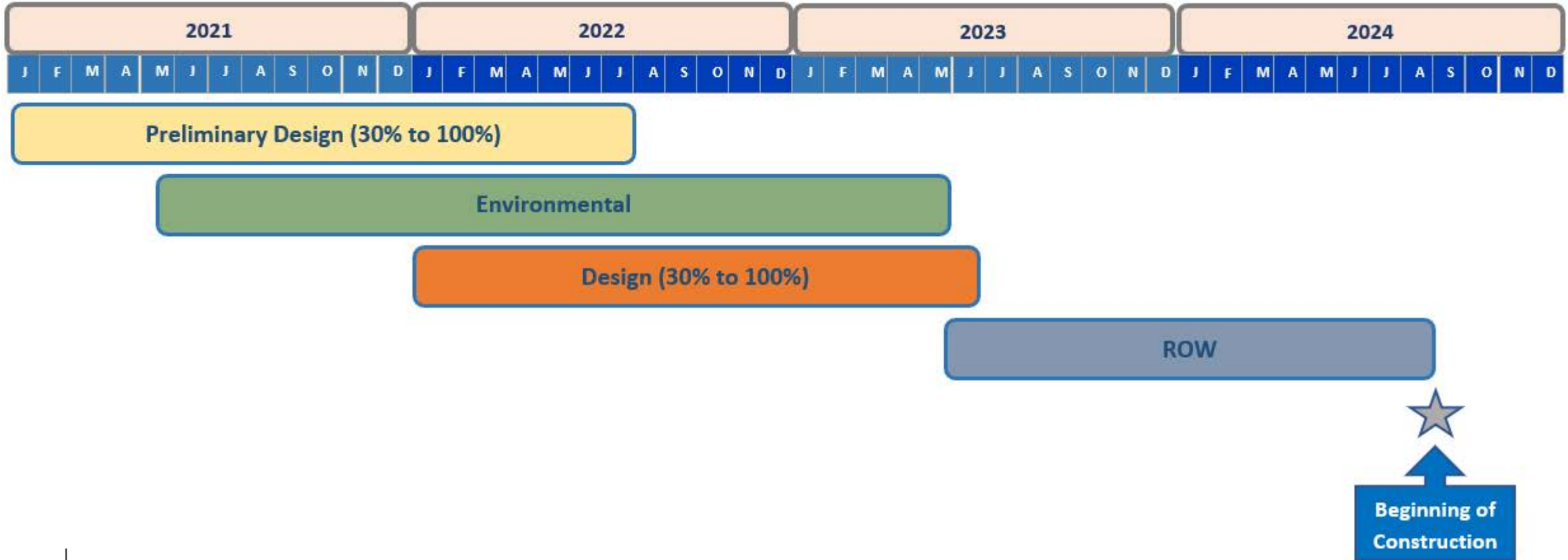

QUESTIONS





Thank you for your attention.